



# Dura-i G3 Single Phase ESS Inverter Standard Install Setup Guide

# **DURACELL**<sup>®</sup> ENERGY

Duracell is a registered trademark of Duracell Batteries BV and Duracell U.S. Operations, Inc., used under license. All rights reserved. Manufactured under license and warranty supported by Puredrive Energy Limited in Toddington, UK.

**Note:** NEITHER DURACELL BATTERIES BV, DURACELL U.S. OPERATIONS, INC., NOR ITS AFFILIATES ARE INVOLVED IN THE DESIGN, MANUFACTURE, MARKETING OR DISTRIBUTION OF THE PRODUCTS AND THEY DO NOT MAKE ANY (AND HEREBY DISCLAIM ALL) EXPRESS OR IMPLIED WARRANTIES RELATING TO THE PRODUCTS.

# Contents

<b>1. Introduction</b> .....	<b>6</b>
<b>2. Safety</b> .....	<b>6</b>
2.1. Symbols	6
2.2. Safety Precautions	8
<b>3. Product Introduction</b> .....	<b>9</b>
3.1. Typical Energy Storage System (ESS)	9
3.2. Supported Grid Types	9
3.2.1. Off-grid Function	10
3.2.2. Off-grid Overload Protection	10
3.3. Product Appearance	11
3.3.1. Dimensions	11
3.3.2. General Description	12
<b>4. Installation</b> .....	<b>13</b>
4.1. Box Contents	13
4.2. Selecting a Location for the Inverter	14
4.2.1. Installation Environment Requirements	14
4.2.2. Installation Clearance Requirements	15
4.2.3. Mounting Requirements	15
4.3. Mounting	16
<b>5. Electrical Connection</b> .....	<b>17</b>
5.1. Standard Install with CT	17
5.2. Standard Install with REM	18
5.3. AC Coupling Connection	19
5.3.1. App Setting Guide for AC Coupling Function	21
5.4. Parallel Application (Between Two & Nine Inverters)	22
5.5. 3-Phase Equipment Connection	25
5.5.1. App Setting Guide For 3-Phase Connection	26
5.6. Net Metering	27
5.6.1. 3-Phase Net Metering - Carlo Gavazzi	27
5.6.2. 3-Phase Net Metering - CHINT	28
5.7. Grounding (Bonding)	29
5.8. GRID Connection	30
5.8.1. GRID Connection Procedure	30

<b>5.9. BACK-UP Connection</b>	<b>31</b>
5.9.1. BACK-UP Connection Procedure	31
<b>5.10. GEN Connection</b>	<b>33</b>
5.10.1. GEN Connection Procedure	33
<b>5.11. Battery Connection</b>	<b>34</b>
<b>5.12. PV Connection</b>	<b>35</b>
<b>6. Communication Interface Connections .....</b>	<b>38</b>
<b>6.1. Interface Layout &amp; Definitions</b>	<b>38</b>
<b>6.2. Terminal Configuration for Monitoring / Meter Communication</b>	<b>39</b>
<b>6.3. CT / Meter Connection Requirements</b>	<b>39</b>
<b>6.4. RS485 Connection</b>	<b>40</b>
6.4.1. RS485 Cable Connection Procedure	40
<b>6.5. CT Cable Connections</b>	<b>42</b>
6.5.1. CT Cable Connection Procedure	42
<b>6.6. Grid Meter Connections</b>	<b>44</b>
6.6.1. Inline Meter Connection	44
6.6.2. CT + Meter Connection	45
6.6.3. Meter Cable Connection Procedure	46
<b>6.7. BMS Connection for the Dura5 Battery (Inverter Side)</b>	<b>48</b>
6.7.1. BMS Communication Cable Connection	50
6.7.2. Parallel Communication Connection	51
6.7.3. Parallel Cable Connection Procedure	51
<b>6.8. Wi-Fi/LAN Dongle Connection</b>	<b>53</b>
<b>6.9. LAN/Wi-Fi Dongle LED status</b>	<b>54</b>
<b>7. System Operation .....</b>	<b>55</b>
<b>7.1. Inverter Working Mode</b>	<b>55</b>
7.1.1. Self-consumption Mode	55
7.1.1.1. Normal Connection	55
7.1.1.2. AC Coupling Connection	58
7.1.2. Feed-in Priority Mode	61
7.1.3. BACK-UP Mode	64
7.1.4. Forced Charge/Discharge Function	67
7.1.5. Off-Grid Mode	67
<b>8. Startup &amp; Shutdown Procedures .....</b>	<b>69</b>
<b>8.1. Inspection</b>	<b>69</b>

8.2. Startup Procedure	69
8.3. Shutdown Procedure	71
<b>9. Commissioning</b> .....	<b>72</b>
9.1. Commissioning Process	72
9.1.1. Access Account Management	73
9.1.2. Start New Commissioning	73
9.1.3. Create Plant & Add Inverter	74
9.2. Complete Quick Setup	76
<b>10. Linking the Plant to the Consumer’s App</b> .....	<b>81</b>
10.1. Download the Duracell Energy App	81
10.2. Battery/Inverter ID Registration	82
10.3. Install at a New Site	83
10.4. Modify the Existing Site	84
10.5. Homeowner Initial Login	85
<b>11. Generator Installation Guide</b> .....	<b>86</b>
11.1. Generator Use	86
11.2. Connections	86
11.2.1. Generator Power Layout	86
11.2.2. Generator Comms Layout	87
11.3. Adding a Generator on the Dura-i App.	89
11.4. Generator Ready	94
11.5. Recommendations	94
<b>12. Maintenance</b> .....	<b>95</b>
12.1. LED Introduction	95
12.2. LAN/Wi-Fi Dongle LED status	95
12.3. Routine Maintenance	97
12.4. Establishing a Local Connection via Bluetooth - Installer	98
12.5. Establishing a Local Connection via Bluetooth - Consumer/End User	101
12.6. Connecting/Reconnecting to Wi-Fi Network - Consumer/End User	104
<b>13. Inverter Troubleshooting</b> .....	<b>105</b>
13.1. Alarm States	105
13.2. Removing the Inverter	110
<b>14. Customer Service Contact Information</b> .....	<b>110</b>

## 1. Introduction

This manual describes the installation, connection, LCD setting, commissioning and maintenance of the single phase Dura-i G3 Energy Storage System (ESS) Inverter. Please first read this manual and related documents carefully before using the product and store it in a place where installation, operation and maintenance personnel can reach it at any time. The illustrations in this user manual are for reference only. This user manual is subject to change without prior notice.

This manual covers the installation for the following Dura-i G3 Single Phase inverters:









- PD-DH1P-3.6K-G1
- PD-DH1P-4.6K-G1
- PD-DH1P-5K-G1
- PD-DH1P-6K-G1

## 2. Safety

Before using the inverter, please read all instructions and cautionary markings on the unit and in this manual. Our ESS inverter strictly conforms to related safety rules in design and test. Please follow local laws and regulations during installation, operation and maintenance. Incorrect operation may cause injury or death to the operator or a third party, and/or damage to the inverter or other properties.

### 2.1. Symbols

The following safety symbols and general information are used on the inverter.

Safety Symbol	Description
	Danger of high voltage! Only qualified personnel may perform work on the inverter.
	Residual voltage exists after the inverter is powered off. It takes 10 minutes for system to discharge to a safe voltage.
	Danger of hot surfaces.
 Do not disconnect under load	Do not disconnect under load, otherwise there will be a danger of fire.
	Environmental Protection Use Period (Years).
	Refer to the operating instructions.
	Do not dispose of the inverter with the household waste.
	Grounding terminal.

This manual incorporates crucial safety instructions that are emphasized using specific symbols. These symbols are employed to ensure the safety of individuals and property during product usage or to assist in maximizing product performance efficiently.

It is essential to thoroughly comprehend the significance of the WARNING symbols to enhance your utilisation of the manual.



**DANGER**

Indicates the presence of high-risk potential hazards that, if not avoided, could result in severe injury or even death.

---



**WARNING**

Indicates the presence of moderate-risk potential hazards that, if not avoided, could result in serious injury or even death.

---



**CAUTION**

Indicates the presence of low-risk potential hazards that, if not avoided, may lead to minor or moderate injury.

---



**NOTICE**

Indicates potential risks that, if not avoided, may result in device malfunctions or financial losses.

---



**NOTE**

Used to indicate supplementary information, emphasized content, or helpful tips that can assist you, such as problem-solving techniques or time-saving suggestions.

---

## 2.2. Safety Precautions

Installation, maintenance and connection of inverters must be performed by qualified personnel, in compliance with local electrical standards, wiring rules and requirements of local power authorities and/or companies.

- The temperature of some parts of the inverter may exceed 60° during operation. Do not touch the inverter during operation to avoid burns.
- Ensure children are kept away from inverters.
- Do not open the front cover of the inverter. Apart from performing work at the wiring terminal (as instructed in this manual), touching or changing components without authorization may cause injury to people, damage to inverters and annulment of the warranty.
- Static electricity may damage electronic components. Appropriate methods must be adopted to prevent such damage to the inverter, otherwise the inverter may be damaged and the warranty annulled.
- Ensure the output voltage of the proposed PV array is lower than the maximum rated input voltage of the inverter; otherwise the inverter may be damaged and the warranty annulled.
- When exposed to sunlight, the PV array generates high DC voltage. Please operate according to our instructions, or it may result in danger to life.
- PV modules should have an IEC61730 class A rating.
- If the equipment is used in a manner not specified by the manufacturer, the protection provided by the equipment may be impaired.
- Completely isolate the inverter before maintenance. Completely isolate the inverter and turn off the PV switch, disconnect the PV terminal, battery terminal, and AC terminal.
- After the inverter is powered off, the remaining electricity and heat may still cause electric shock and burns. Do not touch parts of inverter for 10 minutes after disconnection from the power sources.
- Prohibit inserting or pulling the AC and DC terminals when the inverter is running.
- Do not connect ESS inverter in the following ways:
  - The BACK-UP Port should not be connected to the grid;
  - A single PV panel string should not be connected to two or more inverters.

## 3. Product Introduction

### 3.1. Typical Energy Storage System (ESS)

The Dura-i G3s are high-quality inverters which can convert solar energy to AC energy and store energy into batteries. Typically, an ESS inverter system consists of PV array, ESS inverter, battery and house loads. The system will need internet connectivity via Wi-Fi, LAN or GSM.

The energy generated by inverters can be preferentially supplied to its self-consumption, stored in the battery for future use or fed into the public grid.

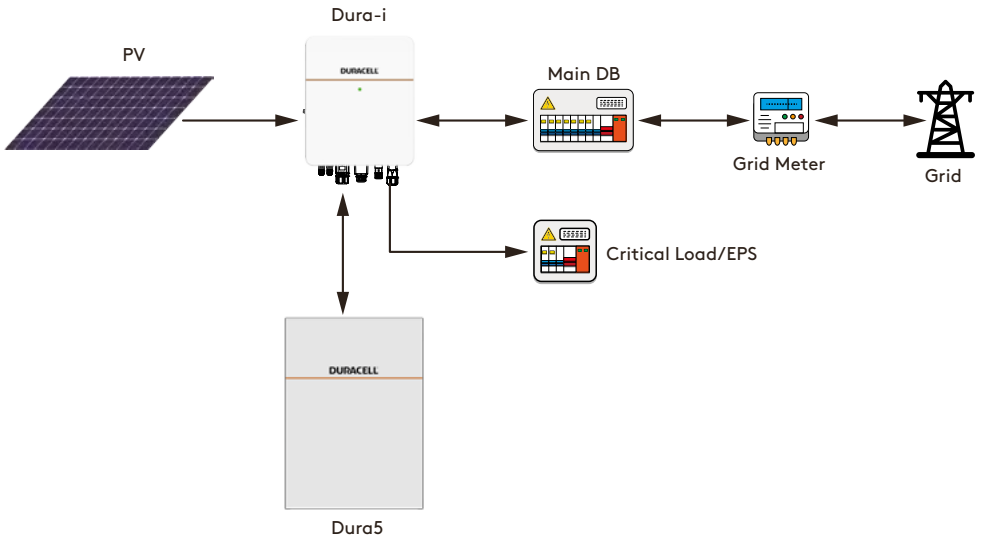

Figure 1.

### 3.2. Supported Grid Types

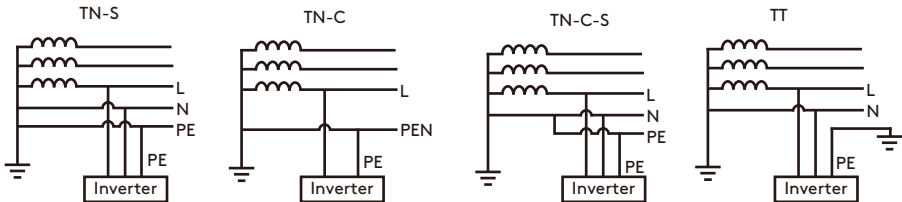

Figure 2.

### 3.2.1. Off-grid Function

The following statement involves Duracell Energy’s general policies about the hybrid inverters described in this document.

- For hybrid inverters, the electrical installation typically includes connection of the inverter to both PV modules and batteries. If there is no available power from batteries or PV modules in off-grid mode, the BACK-UP power supply will be automatically terminated. Duracell Energy shall hold no liability for any consequences arising from failing to observe this instruction.
- Normally, the BACK-UP switching time is less than 10ms. However, some external factors may cause the system to fail in off-grid mode. Therefore, the user must be aware of conditions and follow the instructions as below:
  - Do not connect loads that are dependent on a stable energy supply for a reliable operation.
  - Do not connect loads whose total capacity is greater than the maximum BACK-UP capacity.
  - To prevent the inverter tripping due to overload, do not connect loads that may cause very high start-up current surges, such as air conditioners, high-power pumps, vacuum cleaners, hair driers and electric vehicles.
  - Depending on the condition of the battery, battery current might be limited by some factors, including but not limited to temperature and weather.

### 3.2.2. Off-grid Overload Protection

The inverter has an overload protection safety feature. It will reset itself if the number of allocated Amps is exceeded dependent on the size of the inverter. Reset time is around 3 minutes. If the inverter overloads three times in succession the inverter will be locked and will need a hard restart by holding the on/off button for 1 second to clear the overload alarm. Refer to **Figure 5 on p12**.

Try to reduce BACK-UP load power within maximum limitation or remove any loads which may cause very high start-up current surges.

Inverter	BACK-UP limitation (off-grid)
3.6K	13.1A
4.6K	20A
5K	21.7A
6K	26.1A

**Figure 3.**



**CAUTION**

An additional earth spike/earthing system is a requirement for all critical loads. In the event of an AC outage an earth spike should provide a sufficient earth path for all connected circuits to prevent islanding.

## 3.3. Product Appearance

### 3.3.1. Dimensions

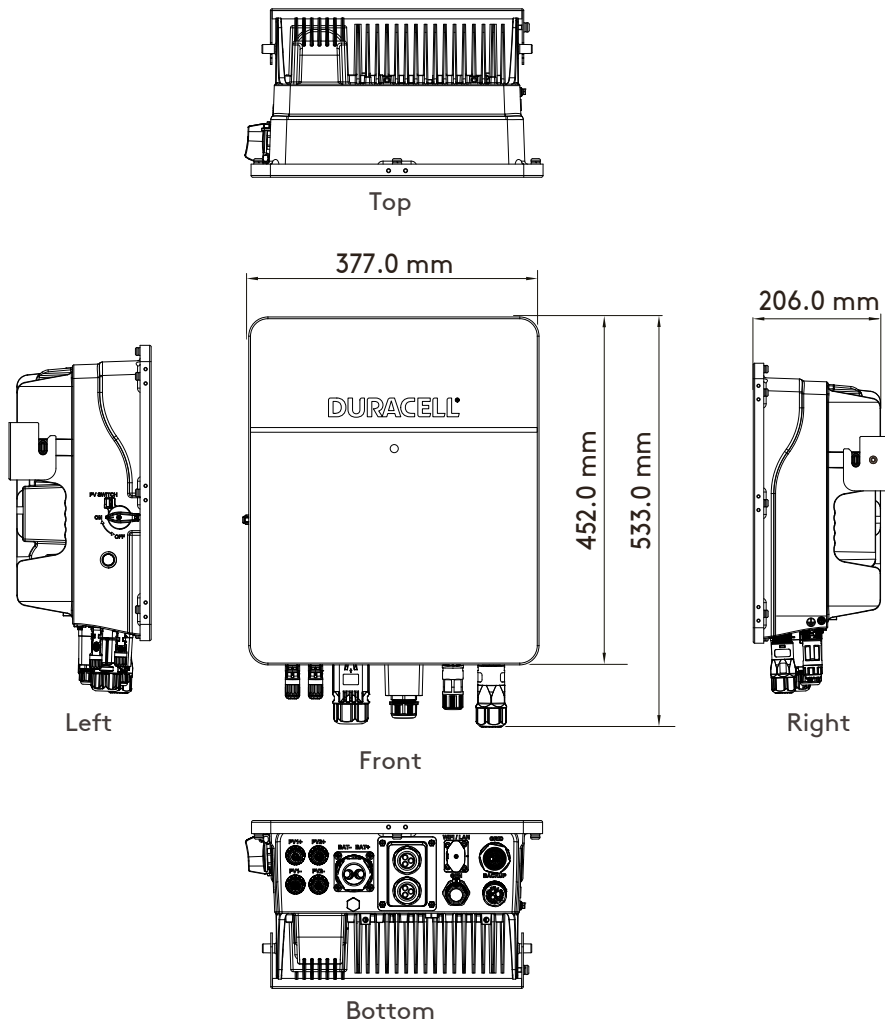

Length (mm)	Height (mm)	Width (mm)
377.0	452.0	206.0

Figure 4.

## 3.3.2. General Description

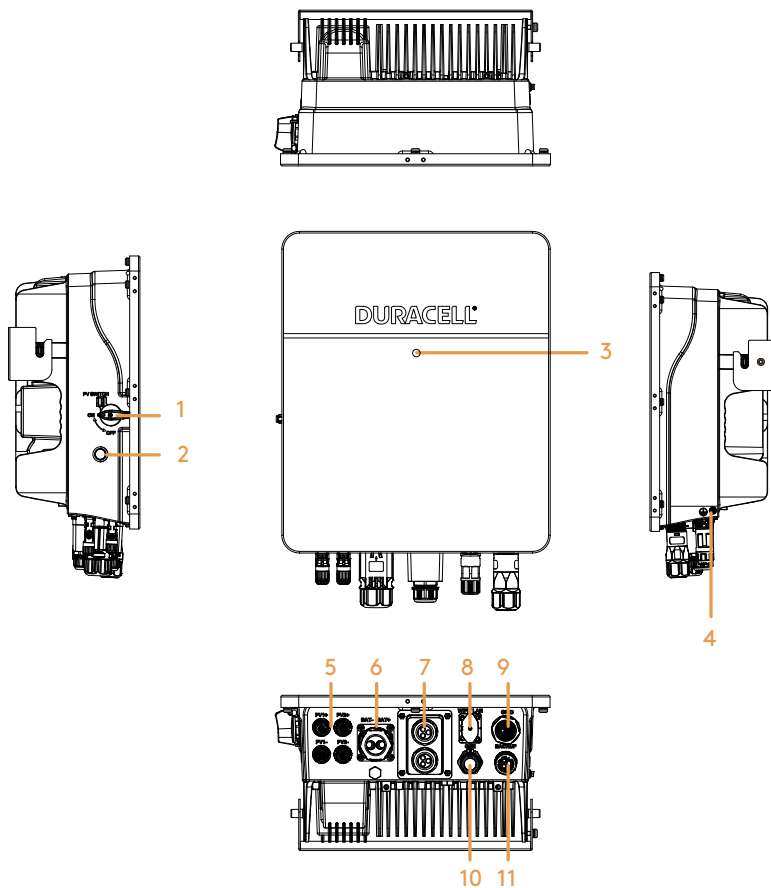

Number	Description
1	PV switch
2	ON/OFF button and instruction label
3	LED indicator
4	Grounding port
5	PV connection port
6	Battery connections

Number	Description
7	Communication port
8	Wi-Fi/LAN port
9	GRID connection port
10	GEN connection port
11	BACK-UP connection port

Figure 5.

## 4. Installation

### 4.1. Box Contents

After unpacking, please check the following packing list carefully for any damage or missing parts.

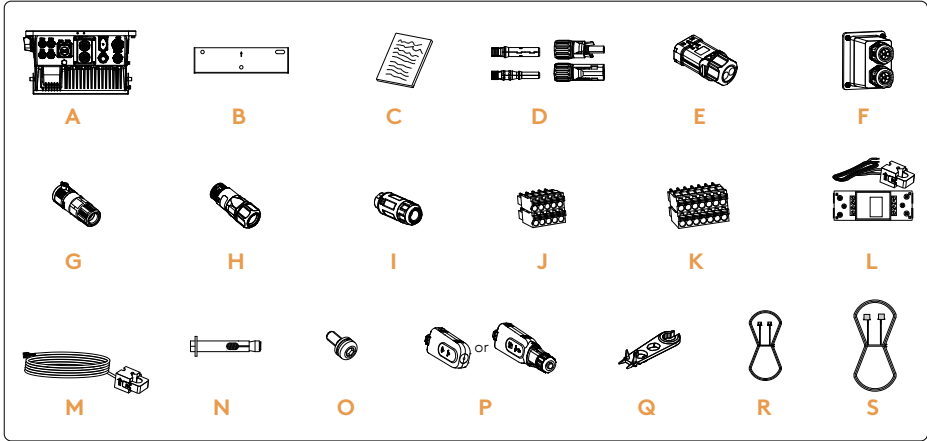

Number	Quantity	Description
A	1	Inverter
B	1	Mounting bracket
C	1	Documentation
D	2/2	PV connector group (PV+/PV-)
E	1	Battery waterproof cover
F	1	COM waterproof cover
G	1	Generator connector plug
H	1	Grid connector plug
I	1	BACK-UP connector plug
J	2	10-Pin terminal
K	1	14-Pin terminal
L	1	CT+ Meter (Optional)
M	1	CT
N	3	M10 Expansion bolt
O	1	M6 Security screw
P	1	Wi-Fi/LAN module
Q	1	Removal tool for PV connector
R	1	BMS to inverter COMMS lead
S	1	Inverter Parallel lead

Figure 6.

## 4.2. Selecting a Location for the Inverter

### 4.2.1. Installation Environment Requirements

- With an IP65 protection rating, the inverter can be mounted indoors or outdoors.
- The mounting location must be inaccessible to unrelated personnel since the enclosure and heat sinks can become extremely hot during operation.
- Do not install the inverter in areas containing flammable materials or gases.
- To ensure optimum operation and long service life, the ambient temperature must be below 50°C.
- The inverter must be mounted in a well-ventilated environment to ensure good heat dissipation.
- The wall where the inverter is mounted must be fire-proof. Do not mount the inverter on flammable building materials.
- Do not install the inverter in a living area due to operational noise.
- The installation height should be reasonable, and please ensure it is accessible.
- Product label and warning symbols should be visible and legible after installation.
- To ensure long service life, the inverter should not be exposed to direct solar radiation, rain, or snow. It is recommended that the inverter be mounted in a sheltered place.

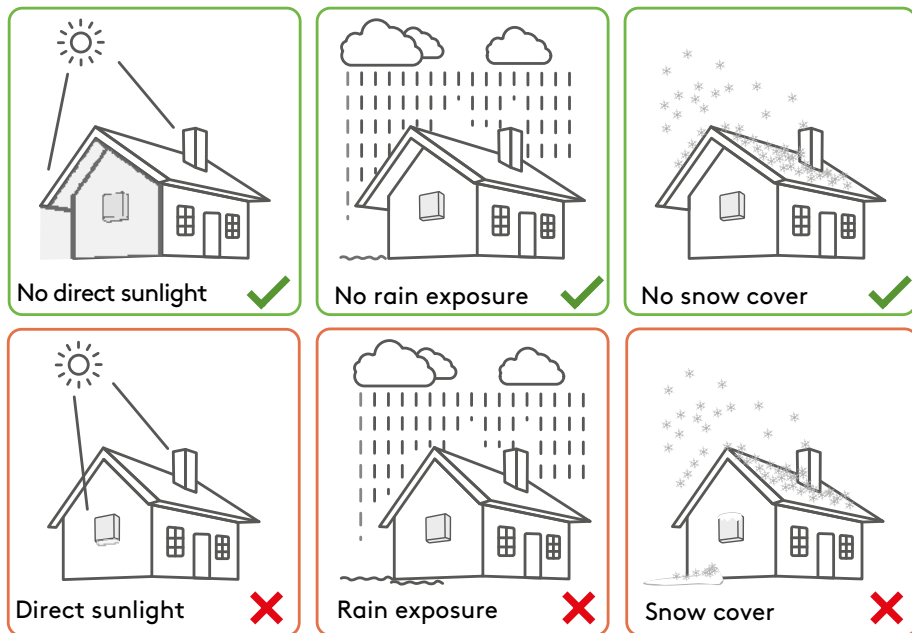

Figure 7.

## 4.2.2. Installation Clearance Requirements

There are clearance requirements on installation of the inverter to ensure the inverter functions properly and to ensure safety and accessibility. Refer to the following figures.

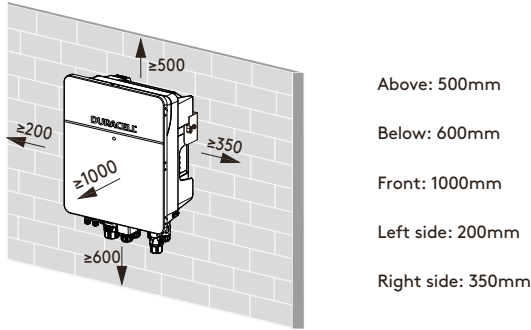

Figure 8.

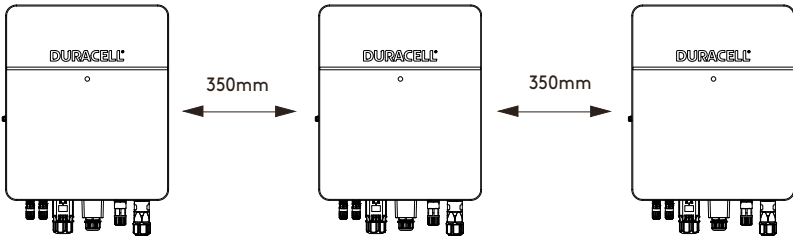

Figure 9. Installation along the same line for multiple inverters.

## 4.2.3. Mounting Requirements

Mount the inverter vertically or tilted backward by no more than 15°. The device cannot be installed if the supporting wall lean is greater than 15° from the vertical. The connecting terminals must point downwards.

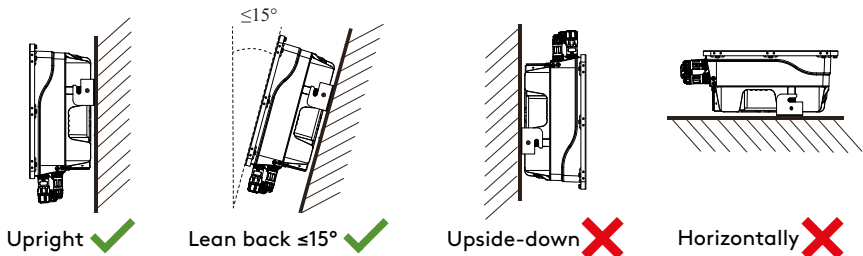

Figure 10.

## 4.3. Mounting

Before mounting the inverter, you have to prepare expansion screws and a security screw.



**DANGER**

Before drilling any holes, ensure there will be no damage to electrical wiring and/or water pipes concealed inside the wall.



**CAUTION**

To prevent potential damage or injury, ensure the inverter is correctly mounted.

### Step 1. Install the mounting bracket

1. Use a level ruler to mark the position of the 3 holes on the wall. Refer to Figure a. And drill 3 holes, 12mm in diameter and 60mm in depth. Refer to **Figure 12, (2)**.

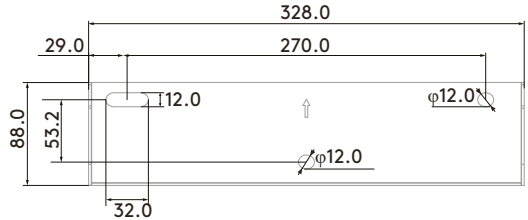

Figure 11.

2. Using a hammer to tap the expansion bolt kit into the hole. Refer to **Figure 12, (3)**. Do not disassemble the expansion bolt - before tapping the expansion bolt into the hole, tighten the bolt with an extra 1-2 turns to prevent dust accumulation.
3. After tightening the 3 bolts, then unscrew the threaded bolts. Refer to **Figure 12, (3)**.
4. Install and fix the mounting bracket on the wall. Refer to **Figure 12, (4)**.

**Step 1. Install the inverter on the mounting bracket. Then lock the inverter using the security screw. Refer to Figure 12, (5) & (6).**

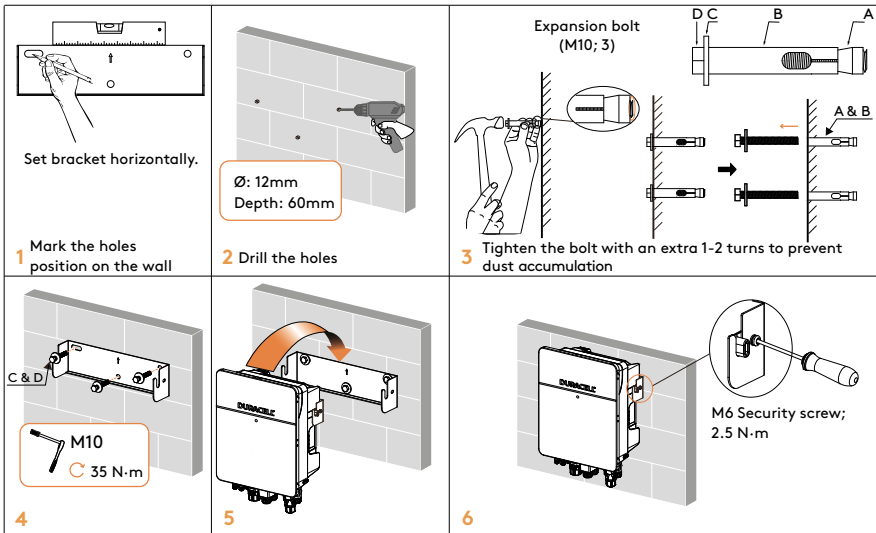

Figure 12.

## 5. Electrical Connection

This chapter shows details of connection of the Dura-i G3.



**DANGER**

Ensure that inverter and all cables to be installed are completely powered off during installation and connection. Otherwise, high voltage may result in fatal injury.

### 5.1. Standard Install with CT

There are three ways to measure the grid voltage and current: Standard install with CT [Figure 13 on p17](#), inline meter [Figure 61 on p44](#) and CT + meter [Figure 62 on p45](#).

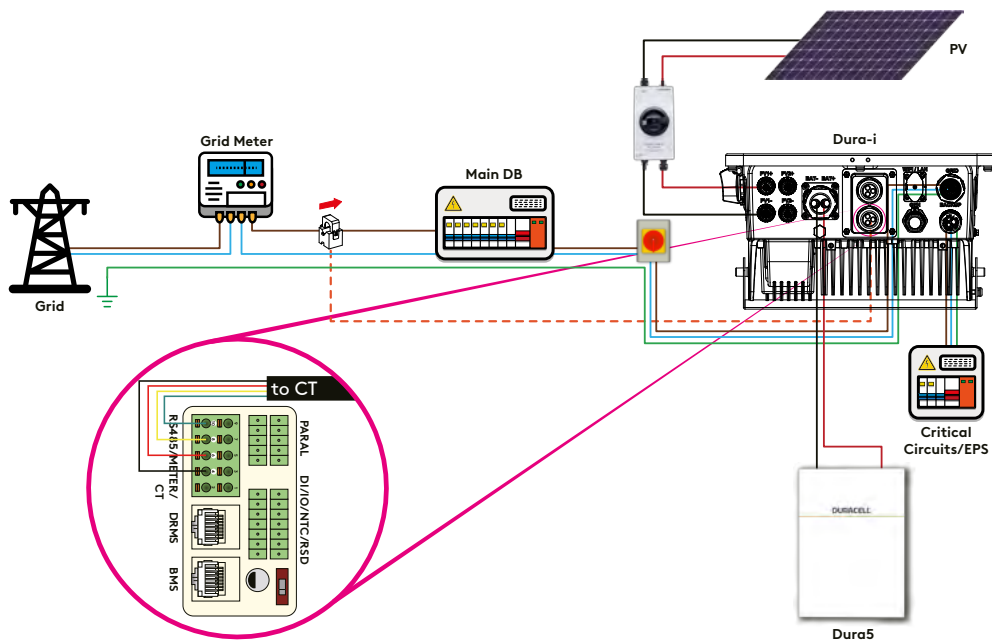

**Figure 13.** Standard install with CT

Please pay attention to the direction of current transformer (CT). The arrow on the CT indicates the current flow from grid to inverter.



**NOTICE**

The current direction from grid to inverter is defined as positive and current direction from inverter to grid is defined as negative.

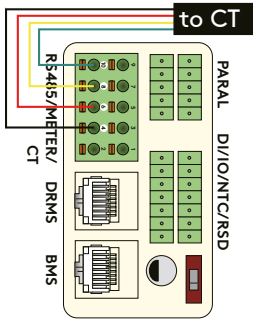

Pin (Terminal)	Function Description
4	GND_S (for CT)
6	L_CT+ (for CT)
8	+3.3V (for CT)
10	CT_DET (for CT)

Figure 14. Pin definition of terminal block labelled RS485/METER/CT

## 5.2. Standard Install with REM

For more detail on REM Grid Metering, refer to the dedicated [REM Grid Meter Guide for Dura-i G3](#).

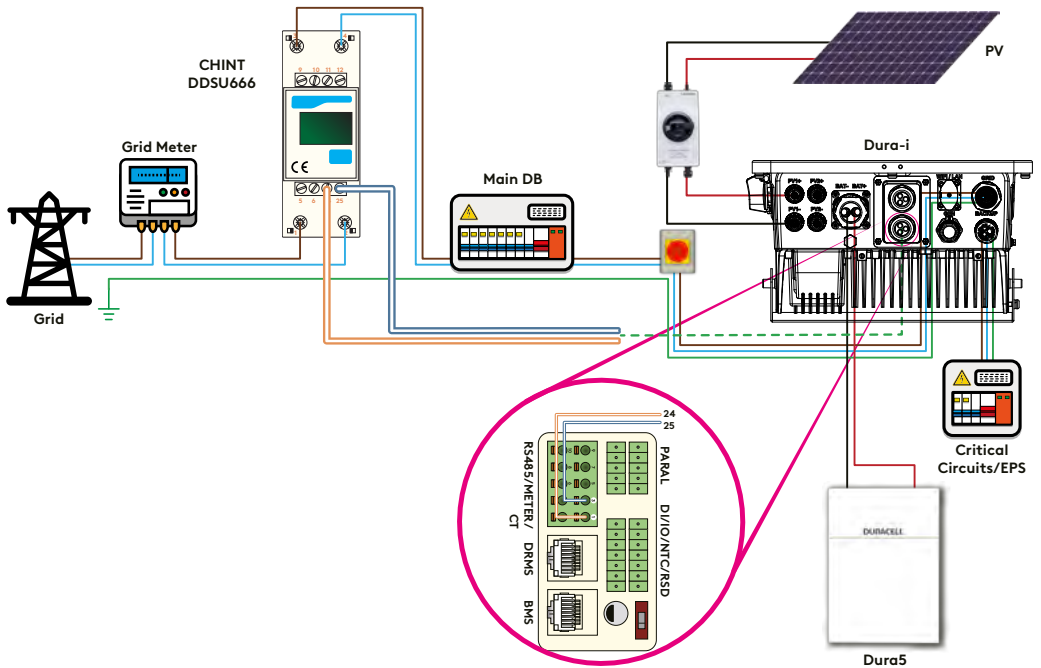

Figure 15. Standard install with REM



NOTE

- BMS communication connection is only for the Dura5 battery.
- Meter is optional.
- When connecting an inline meter, the single phase CHINT meter is only suitable for up to 80A.

Inverter	Battery breaker	BACK-UP breaker/Gen breaker	AC requirement
3.6K	100 A / 80 V DC	13.1A	18A
4.6K	150 A / 80 V DC	20A	21A
5K		21.7A	25A
6K	175 A / 80 V DC	26.1A	28.7A

Figure 16. Breakers recommendation

### 5.3. AC Coupling Connection

For more detail on AC Coupling, refer to the dedicated [AC Couple Function For Dura-i G3 manual](#).

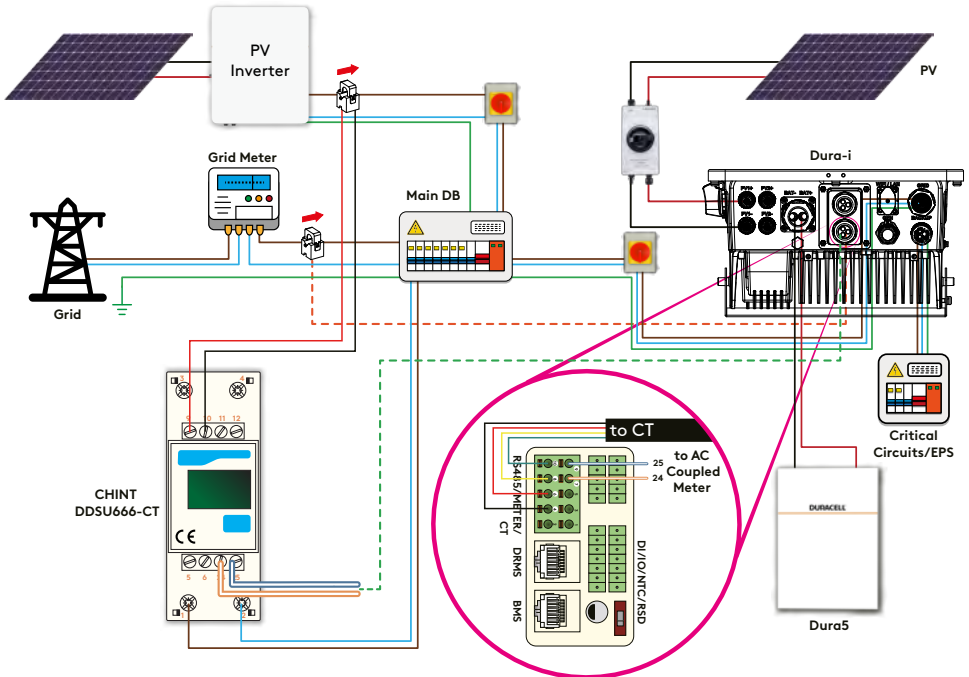

Figure 17. AC Coupling Connection Wiring Diagram with CHINT

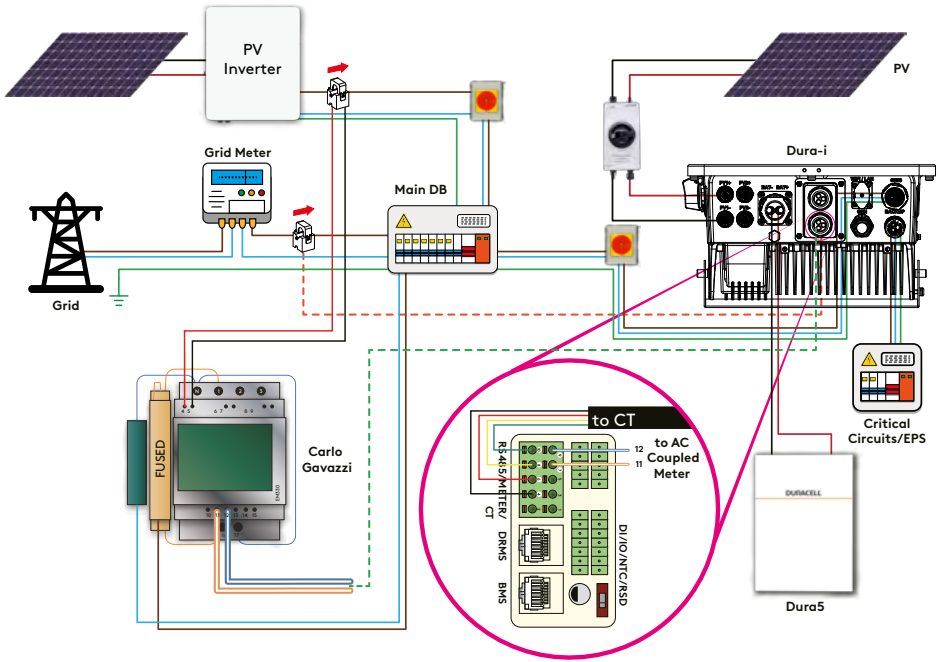
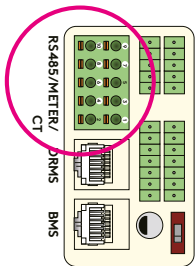

Figure 18. AC Coupling Connection Wiring Diagram with Carlo Gavazzi



NOTE

- When connecting the meter, the phase of the meter should be consistent with that of the ESS/PV inverter.
- Ensure that meter 1 and meter 2 are wired properly and correctly, otherwise unpredictable problems may occur.
- If the current flowing through the meter is too high, use CT + REM.



Pin	Function Description	Pin	Function Description
1	RS485_A1 (for Meter 1)	4	LCT- (for CT)
2	Unused	5	Unused
3	RS485_B1 (for Meter 1)	6	LCT+ (for CT)
7	RS485_A2 (for Meter 2)	8	+3.3V (for CT)
9	RS485_B2 (for Meter 2)	10	CT_DET (for CT)

Figure 19. The CT, meter 1 and meter 2 communication pin definition for the 10-point terminal block. This clicks into the port labelled RS485/METER/CT within the COMMS section of the Dura-i.

### 5.3.1. App Setting Guide for AC Coupling Function

In order to enable AC coupling function, it is necessary to connect the App to each inverter and set related parameters.

**Step 1. Login as an administrator.**

**Step 2. Tap Setting > Inverter > Other to enable AC coupling function and set meter 2. See Figure 20, (a)-(b).**

**Step 3. Tap Quick Settings > Power limit to set power control (meter 1) and select meter type. CT sensor is selected by default.**

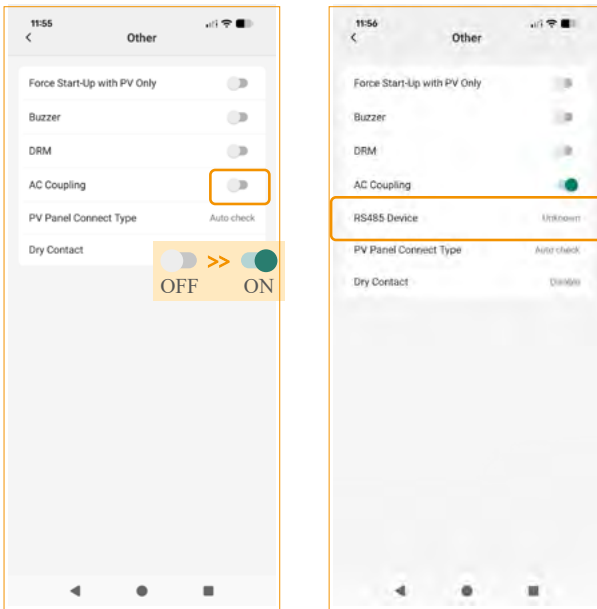

**Figure 20.** Left - (a) - Enable. Right - (b) Set meter 2.

## 5.4. Parallel Application (Between Two & Nine Inverters)

For more detail on Parallel Setup refer to the dedicated [Parallel Setup Guide for Dura-i G3](#).

- BMS communication connection is only for the Dura5 battery.
- It is necessary to turn the matched resistance switch of inverter No. 1 and inverter No. N to "ON" in parallel connection mode
- With parallel connection mode, it is necessary to connect the App to one of the inverters and then go to **Setting > Inverter > Parallel** page to enable **Parallel mode** on app. Setting/modifying these parameters requires logging into an administrator account.
- In one parallel system, the smart load is only allowed to be connected to GEN port in a non-parallel way.
- In one parallel system, the batteries can be connected independently or in parallel, this manual only shows the batteries connected in parallel. In a system connected with independent batteries, the CT/meter cable can be connected to any inverter of the parallel system and this inverter is the primary inverter, i.e., Inverter No. 1.
- For one parallel system, ensure the conductor's materials, cross-sectional areas, and lengths of AC cables between Inverter No. 1 and other inverters of the system on the BACK-UP port are the same. It is recommended that the length of the cable be less than or equal to 2m.



NOTE

Inverter	Battery breaker	BACK-UP breaker/Gen breaker	AC requirement	Normal load breaker	Main breaker
3.6K	100 A / 80 V DC	13.1A	18A	Depends on household loads	Depends on household loads
4.6K	150 A / 80 V DC	20A	21A		
5K		21.7A	25A		
6K	175 A / 80 V DC	26.1A	28.7A		

## Parallel Application (Between Two & Nine Inverters)

## Electrical Connection

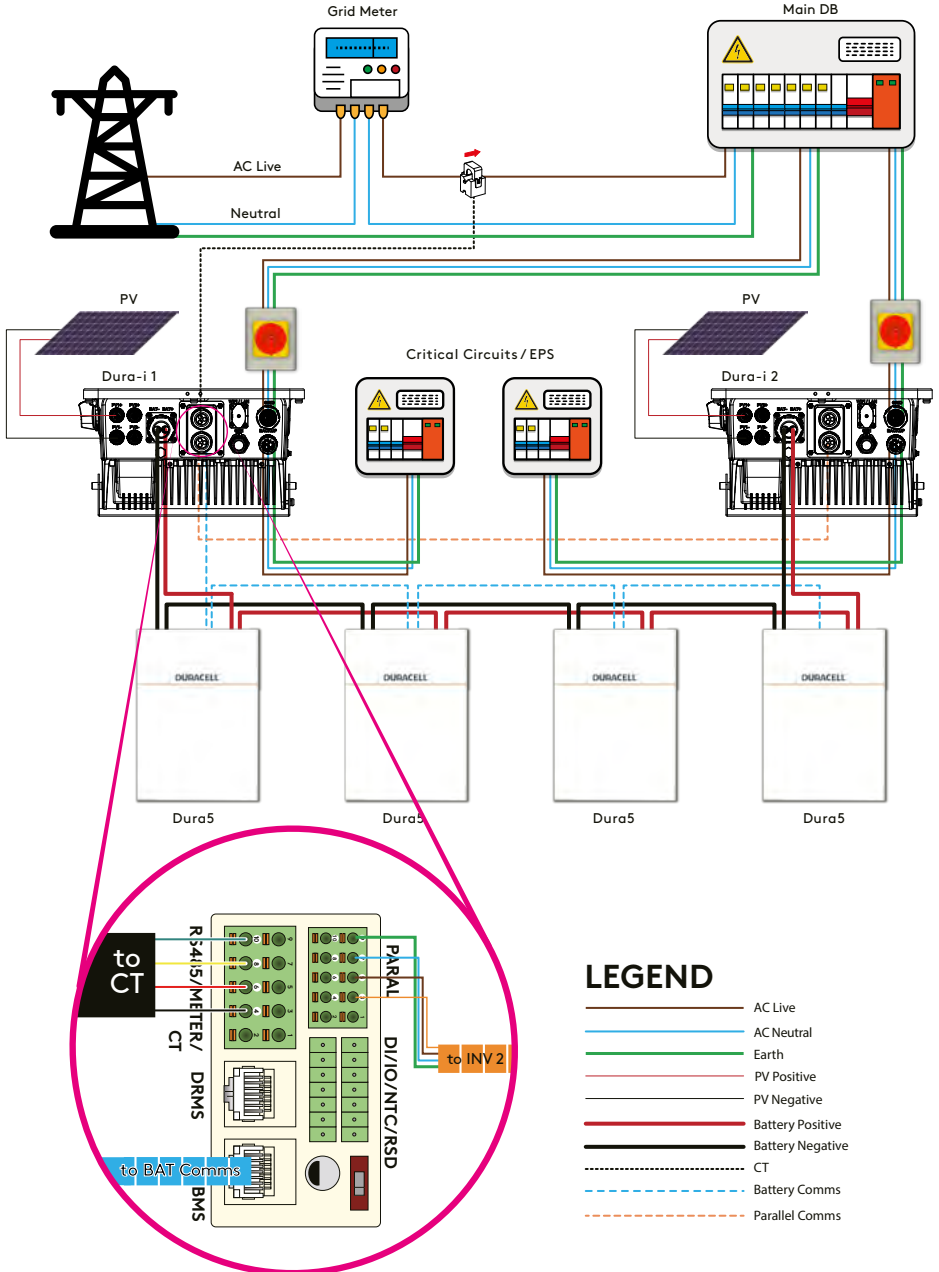

Figure 21. Single phase with batteries in parallel

## Parallel Application (Between Two & Nine Inverters)

## Electrical Connection

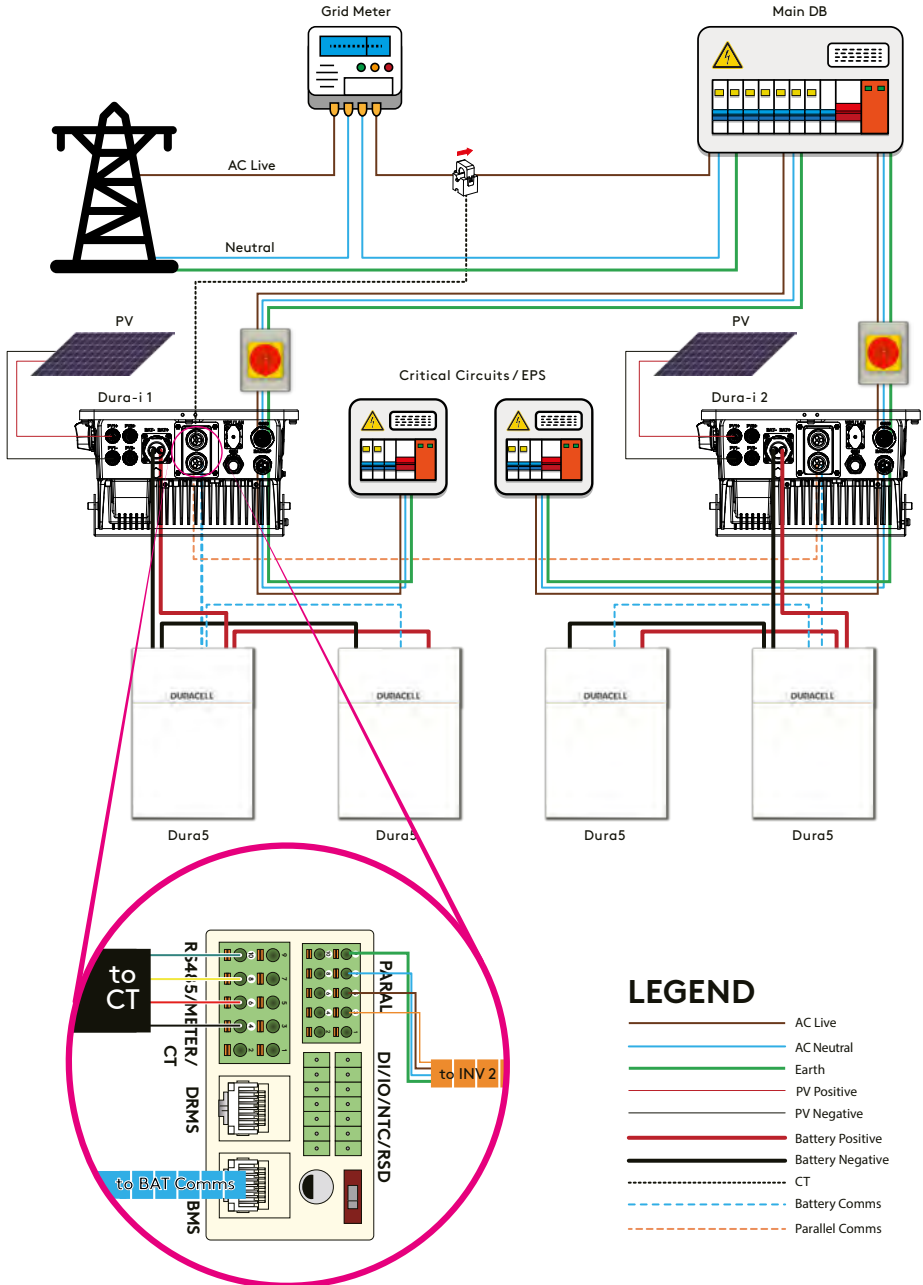

Figure 22. Single Phase parallel with batteries independent

## 5.5. 3-Phase Equipment Connection

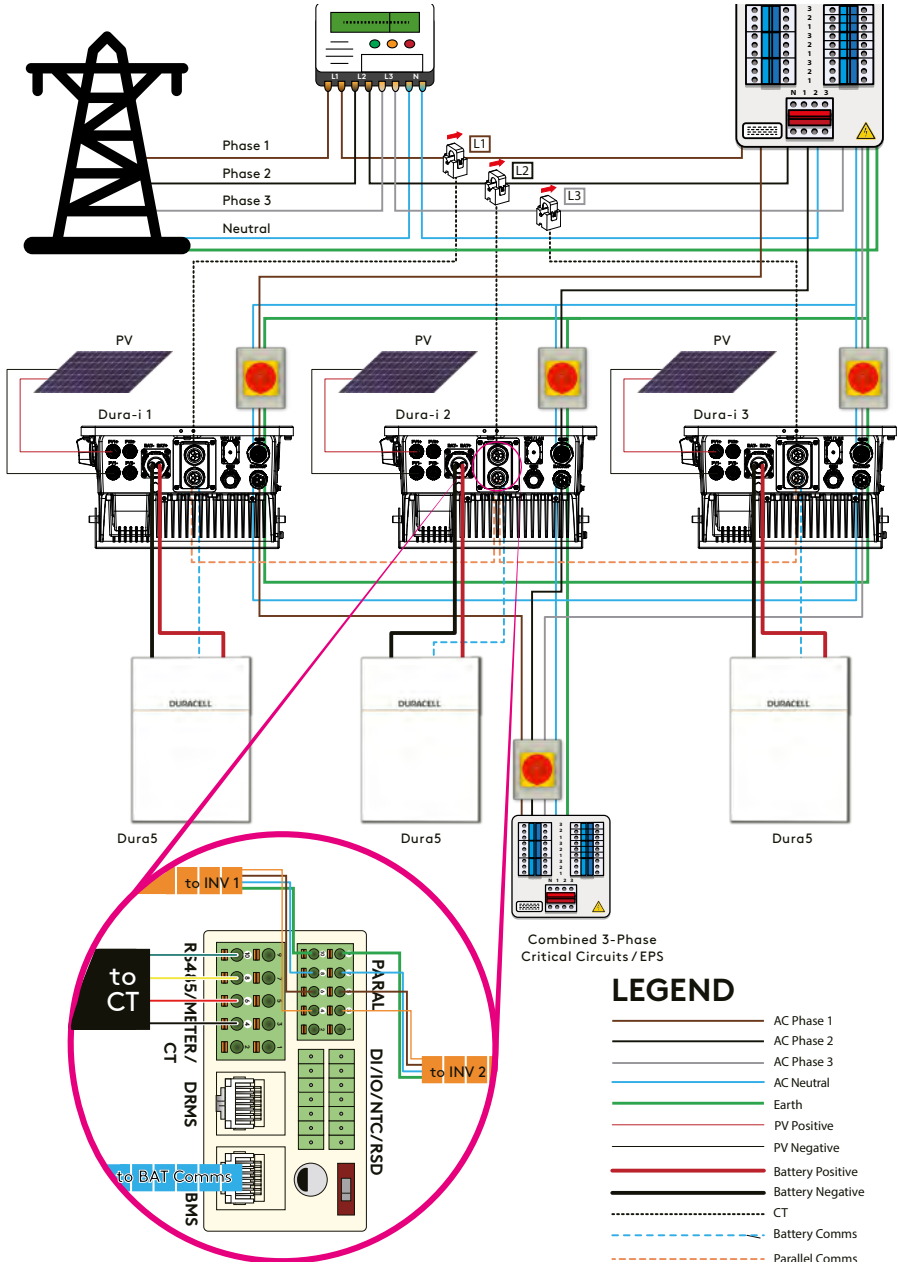

Figure 23. 3-phase Equipment Connection Wiring Diagram (N=3)

- Ensure all inverters in parallel have the same firmware version by verifying the 'Primary DSP', 'Secondary DSP', and 'CSB' version numbers in the app.
- A maximum of 3 single-phase inverters are connected to form a 3-phase system and each inverter supports one phase only.



**NOTE**

- BMS connection is only applicable to the Dura5 battery .
  - For shared Dura5 battery connection, please refer to 3-phase equipment connection wiring diagram on **p25** to connect the BMS communication cable.
  - For independent Dura5 battery connection, the BMS communication cable should be connected to every inverter.

### 5.5.1. App Setting Guide For 3-Phase Connection

Under 3-phase connection mode, it is necessary to connect the App to each inverter and set related parameters. The following is an example for three inverters.

**Step 1. Login as an administrator.**

**Step 2. Go to **Setting > Inverter > Parallel** to enable Parallel Mode.**

**Step 3. Set the battery connect type: **Setting > Inverter > Parallel > Battery Connection Type > Select Parallel or Independent.****

**Step 4. Set the phase position accordingly: Go to **Setting > Inverter > Parallel > Single to 3-Phase**. Notice that all three inverters should be set in this step. See **Figure 24, (a)-(c)**.**

**Step 5. Set the other basic parameters of the inverter. For full commission please complete the Quick Setup.**

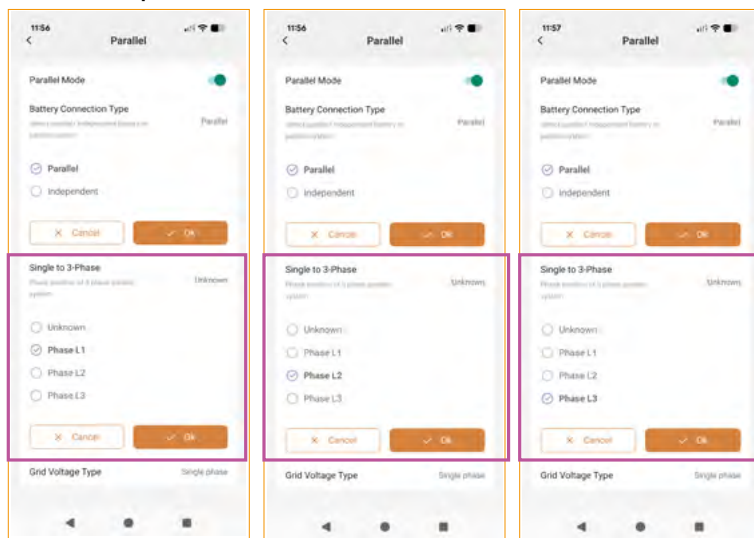

**Figure 24.** Left (a) - P1-Phase L1. Centre -(b) P2-Phase L2. Right -(c) P3-Phase L3

## 5.6. Net Metering

For more detail on Net Metering please refer to the dedicated document **3-Phase Net Metering for Dura-i G3**.

### 5.6.1. 3-Phase Net Metering - Carlo Gavazzi

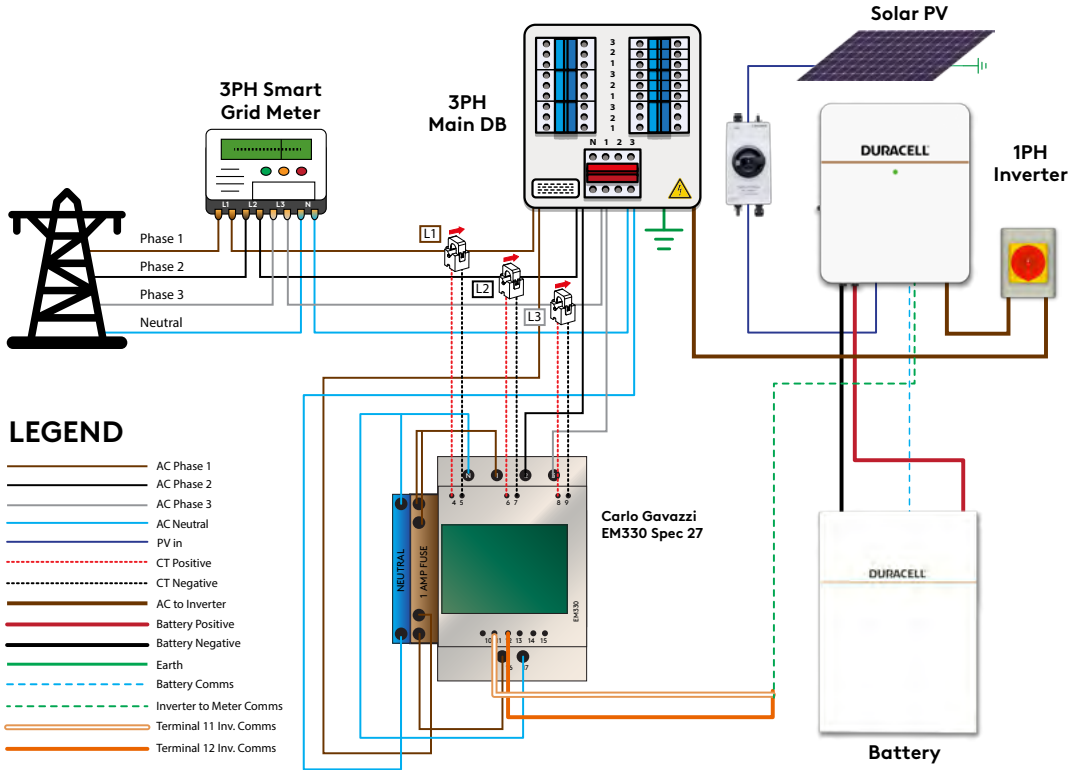

Figure 25. 3-Phase Net Metering Wiring Layout, Carlo Gavazzi

## 5.6.2. 3-Phase Net Metering - CHINT

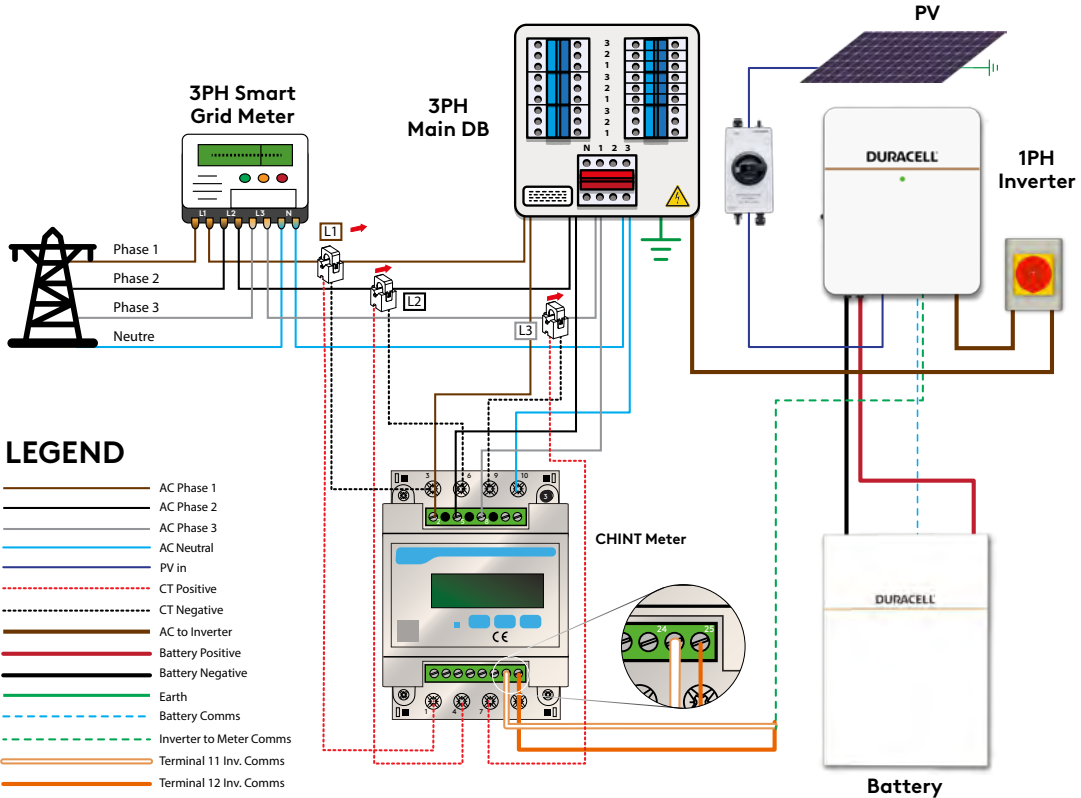

Figure 26. 3-Phase Net Metering Wiring Layout, CHINT

### 5.7. Grounding (Bonding)

The Dura-i G3 is equipped with a protective earth (PE) terminal. Please be sure to connect this PE terminal to the PE bar for reliable grounding. Ensure the cross section area of green-yellow wire is greater than or equal to 10mm<sup>2</sup>.



**WARNING**

The inverter must be grounded; otherwise, there may be risk of electric shock.



**CAUTION**

If the positive pole or negative pole of the PV array is required to be grounded, then the inverter output (to AC grid) must be isolated by transformer in accordance with IEC62109-1, -2 standards.

Items	Remark
Screw	M4 X 10 mm; 1.2 N·m
Cross-sectional area (Green-yellow wire)	S (Green-yellow wire) ≥ S (PE wire of AC cable) S is the cross-sectional area.
	≥ 10mm <sup>2</sup> OT terminal must be sized to cross-sectional area of green-yellow wire. E.g., if the cross-sectional area of green-yellow wire is 10mm <sup>2</sup> , OT8-4 terminal should be chosen.

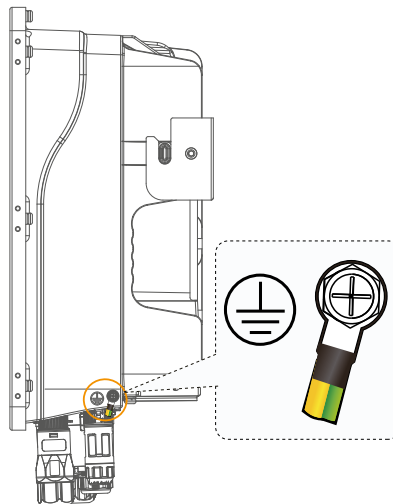

Figure 27. Right-side view

## 5.8. GRID Connection

Before connecting the GRID terminal, ensure that both the AC terminal and the DC terminal are powered OFF and the PV switch is OFF. Otherwise there is a risk of high voltage shock.

### 5.8.1. GRID Connection Procedure

#### Step 1. Select the cable.

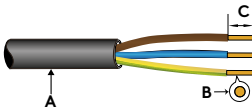

A. Diameter	11.8-16.8 mm
B. Cross Section	8-10 mm <sup>2</sup>
C. Strip Length	~10 mm

It is recommended to use outdoor dedicated cables with multiple copper cores.

Figure 28.

#### Step 2. Thread the cable.

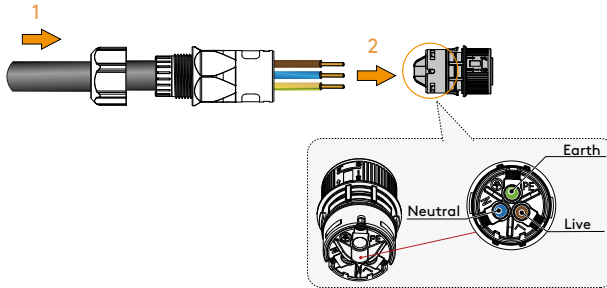

Figure 29.



**NOTE**

If the wires do not pass through, remove the orange seal from the threaded sleeve. If the wires still do not pass through, remove the blue seal.

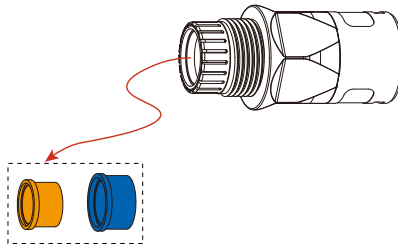

Figure 30.

**Step 3. Tighten the three terminal screws.**

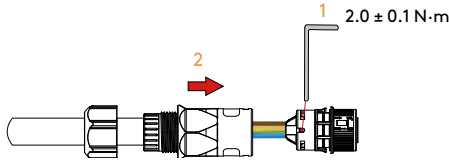

Figure 31.

**Step 4. Install the connector to the "GRID" port.**

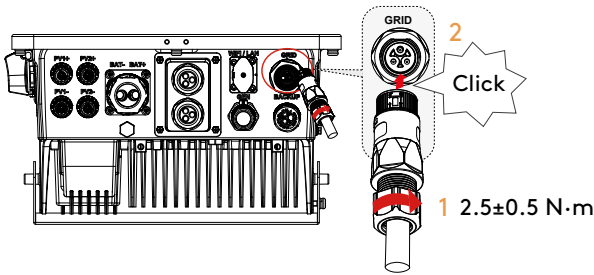

Figure 32.

## 5.9. BACK-UP Connection

Before connecting the BACK-UP terminal, ensure that both the AC terminal and the DC terminal are powered OFF and the PV switch is OFF. Otherwise there is a risk of high voltage shock.

### 5.9.1. BACK-UP Connection Procedure

**Step 1. Select the cable.**

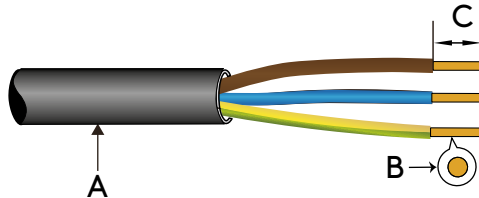

A	B	C
Diameter 11.5-13.5 mm	Cross Section 5.3-6 mm <sup>2</sup>	Strip Length ~10 mm

Figure 33. It is recommended to use outdoor dedicated cables with multiple copper cores.

**Step 2. Thread the cable.**

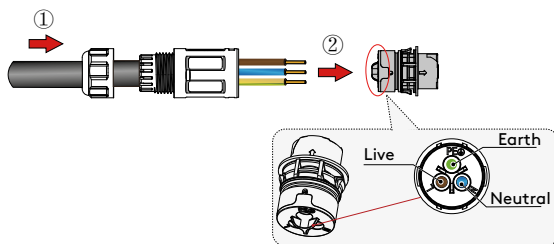

Figure 34.

**Step 3. Tighten the three terminal screws.**

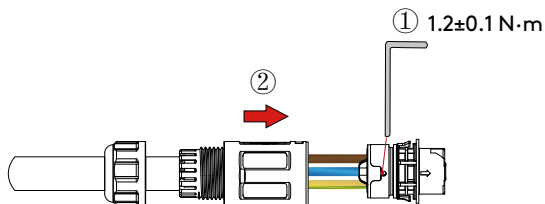

Figure 35.

**Step 4. Install the connector to the "BACK-UP" port.**

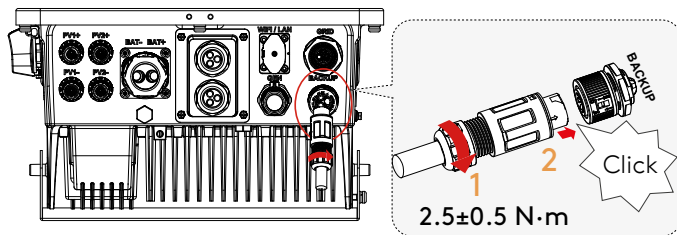

Figure 36.

## 5.10. GEN Connection

Before connecting the GEN terminal, ensure that both the AC terminal and the DC terminal are powered OFF and the PV switch is OFF. Otherwise there is a risk of high voltage shock.

### 5.10.1. GEN Connection Procedure

**Step 1. Select the cable.**

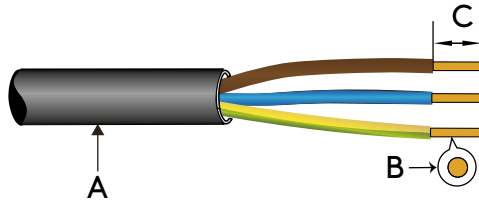

A	B	C
Diameter 11.5-13.5 mm	Cross Section 5.3-6 mm <sup>2</sup>	Strip Length ~10 mm

*Figure 37. Using outdoor-dedicated cables with multiple copper cores is recommended.*

**Step 2. Thread the cable and crimp the wire ferrules.**

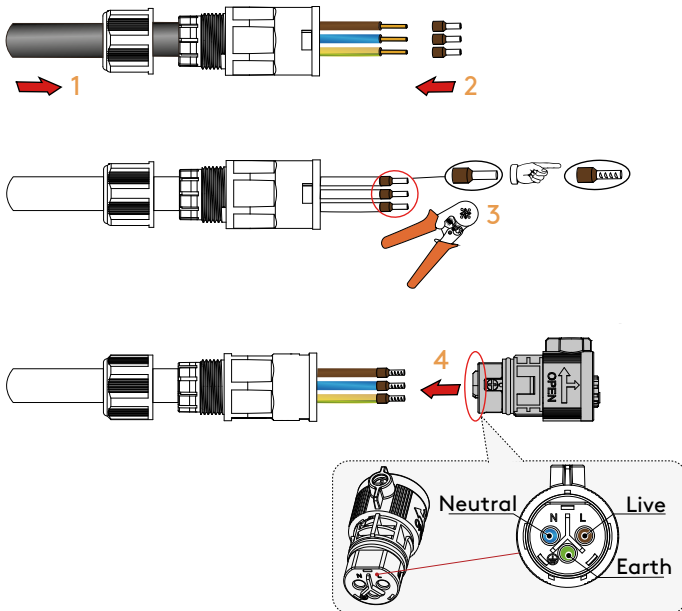

*Figure 38.*

**Step 3. Tighten the three terminal screws.**

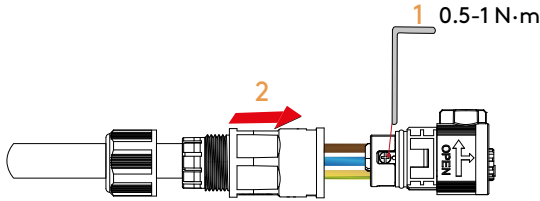

Figure 39.

**Step 4. Install the connector to the "GEN" port.**

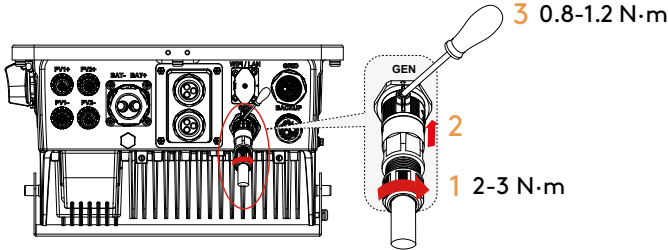

Figure 40.

## 5.11. Battery Connection

This section explains the requirements and procedures of battery connection. Read carefully before connecting.



**DANGER**

Before connecting the battery terminal, ensure that both the AC terminal and the DC terminal are powered off and the PV switch is OFF. Otherwise there is a risk of high voltage shock.

**Step 1. Prepare the proper cable and strip an appropriate length of the cable insulation.**

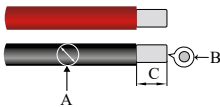

Model	A	B	C
3.6K	9-10.5 mm	16-21.2 mm <sup>2</sup>	~20 mm
4.6K/5K/6K		25-26.7 mm <sup>2</sup>	

Figure 41.

**Step 2. Thread the wires.**

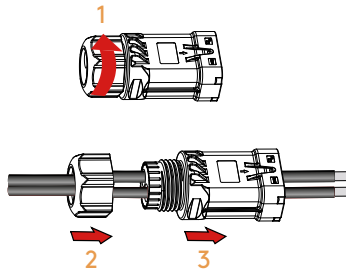

Figure 42.

**Step 3. Insert the wires into the rubber core according to the line sequence and put the cable in place.**

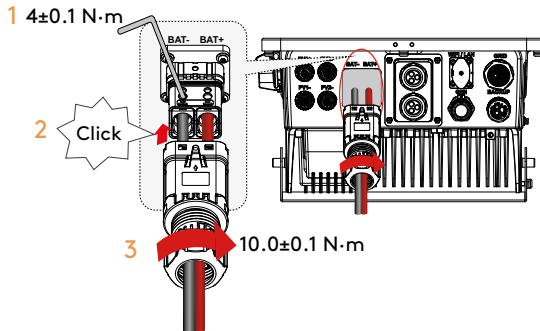

Figure 43.

## 5.12. PV Connection



**WARNING**

Please check polarity of the PV connectors!  
If polarity is reversed, do not try to disconnect any PV connector until the charge declines and the DC currents fall below 0.5 A!  
Only then disconnect the PV plugs and correct the polarity before reconnecting.



**NOTICE**

Before connection the PV panels, make sure the plug connector has the correct polarity. Incorrect polarity could permanently damage the inverter. PV array shouldn't be connected to ground of the grounding conductor. The minimum insulation resistance to ground of the PV panels must exceed 18.33kΩ, there is a risk of shock hazard if the requirement of minimum resistance is not met.

For PV connection please refer to the following steps.

**Step 1. MC4 terminations.**



**NOTE** PV cable should be dedicated PV cable (suggest using 4 - 6mm<sup>2</sup> PV1-F cable).

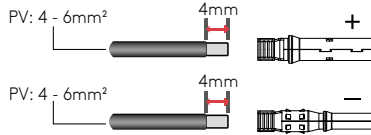

**Figure 44.** MC4 terminations

**Step 2.** Insert the exposed areas of the positive and negative cables into the metal terminals of the positive and negative connectors respectively, and crimp them with a crimping tool. Then insert the crimped positive and negative cables into the corresponding positive and negative connectors.

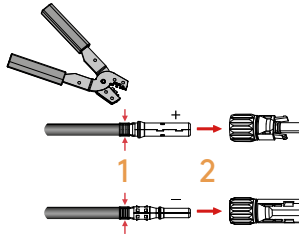

**Figure 45.**

**Step 3.** Tighten the waterproof nuts on each connector with a tool to avoid loosening.

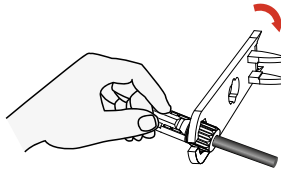

**Figure 46.**

**Step 4.** Test string voltage and confirm string polarity.

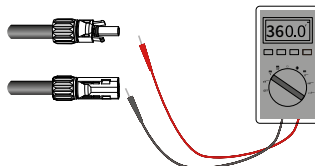

**Figure 47.**

**Step 5.** Ensure that the PV switch is OFF.

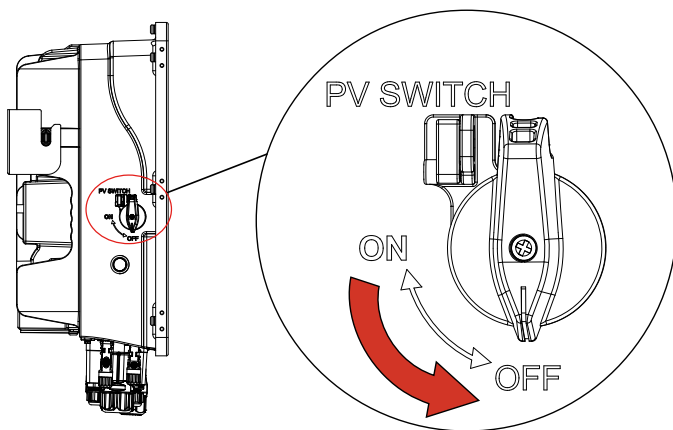

Figure 48.

**Step 6.** Insert the positive and negative connectors into the PV+/PV- ports until a “click” sound is heard.

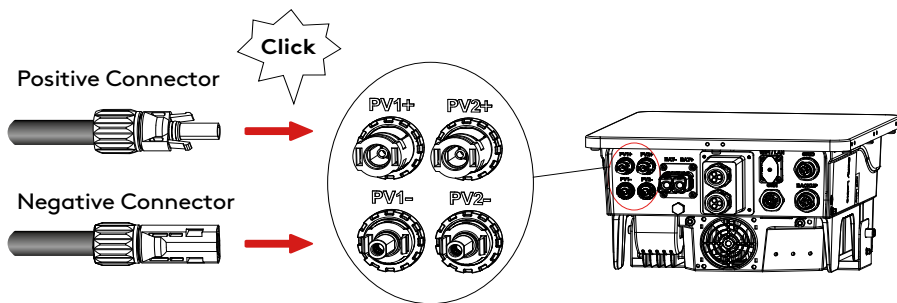
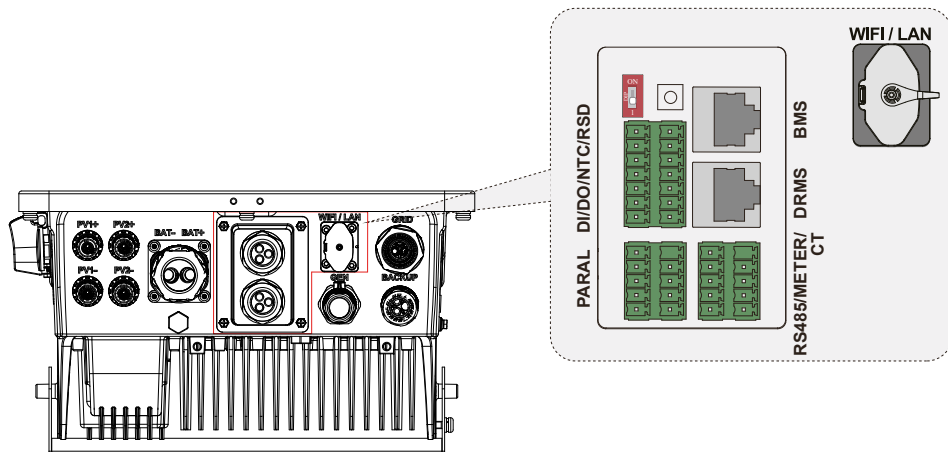

Figure 49.

## 6. Communication Interface Connections

### 6.1. Interface Layout & Definitions



Interface		Description
BMS		The Dura5 battery communication interface.
DRMS		Demand response mode for Australia application.
RS485/METER/CT		RS485 communication (monitor/meter) or Grid current sense.
PARAL		10-Pin interface for parallel communication. A matched resistance switch for parallel communication.
14-Pin	DI	Dry contact input1/2 control (reserved).
	DO	Dry contact output1/2 control(reserved).
	NTC	Temperature sensor terminal of lead-acid battery.
	RSD	RSD control power and remote off.
Wi-Fi/LAN		For Wi-Fi/LAN communication.

**Figure 50.** Communication interfaces layout and definition

## 6.2. Terminal Configuration for Monitoring / Meter Communication

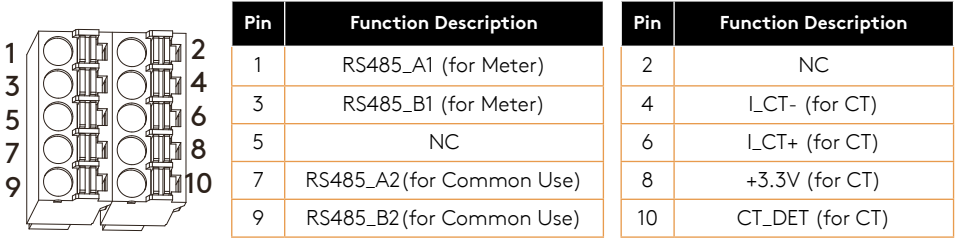

*Figure 51.*

## 6.3. CT/Meter Connection Requirements

Inverter	Distance	CT	Extended CT	REM inline	REM meter with CT	Legend	
Primary	≤ 3m	✓		✓	✓	✓	available
	3 - 10m	✓		✓	✓	✓	
	10 - 25m		✓	✓	✓	✓	
	> 25m			✓	✓	✓	
						✓	preferable

*Figure 52. Available options for grid monitoring*



NOTE

- 10m cable length. If required you may extend the CT cable up to a further 15m (Max total 25m).
- This cable must be run **at least 200mm distance** from any power cables and other sources of EMI. **If power cables must be crossed by the CT wiring, they must cross at a 90° angle.**



NOTE

- Meter (optional): wire length up to 100m.
- For CT + Meter connection, it is necessary to additionally purchase suitable CT and meter from customer services.



NOTE

For the inverter to retain its IP65 rating, the CT communication cable must be correctly fitted to the waterproof cover.

### 6.4. RS485 Connection

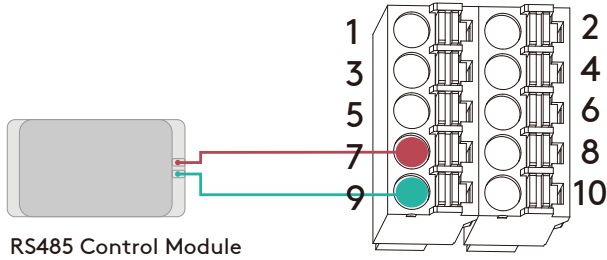

Pin (Terminal)	Function Description
7	RS485_A2
9	RS485_B2

Figure 53.

#### 6.4.1. RS485 Cable Connection Procedure

**Step 1.** Unscrew the waterproof cover, then loosen the rubber nut and finally remove the sealing plugs.

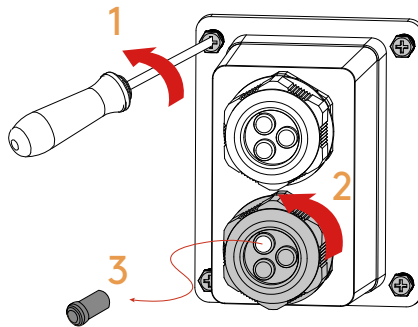

Figure 54.

**Step 2.** Thread the cables and make the terminal.

1. Lead the cable through the rubber nut, seal and waterproof cover in turn.
2. Make the terminal according to the above pin definition.

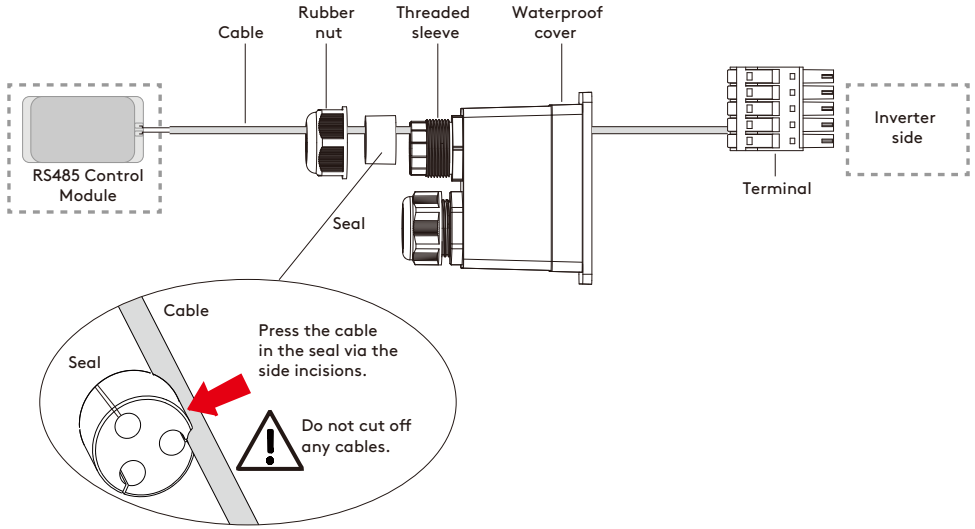

Figure 55.

### Step 3. Insert the terminal.

1. Insert the terminal into its corresponding port.
2. Screw the waterproof cover back into the inverter firmly with 4 x M4 screws (1.2N·m).
3. Install the seal into the threaded sleeve and fasten the rubber nut.

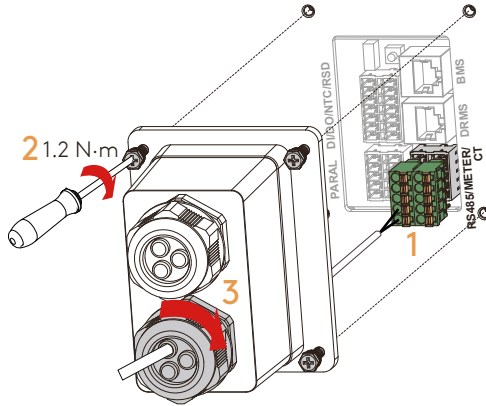

Figure 56.

## 6.5. CT Cable Connections



**NOTE** Ensure that the inverter is completely powered off before connecting the CT cable.

### 6.5.1. CT Cable Connection Procedure

**Step 1.** Unscrew the waterproof cover, then loosen the rubber nut and finally remove the sealing plugs.

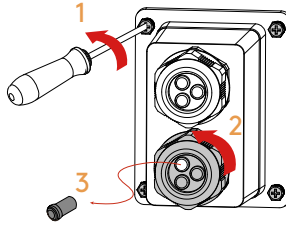
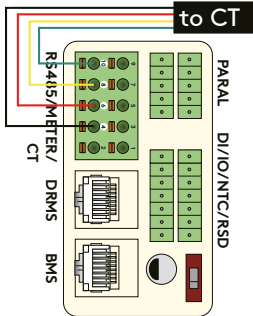

Figure 57.

**Step 2.** Thread the cables and connect them.



Pin (Terminal)	Function Description
4	GND_S (for CT)
6	L_CT+ (for CT)
8	+3.3V (for CT)
10	CT_DET (for CT)

Figure 58.

1. Thread the cable through the rubber nut, seal and waterproof cover in turn.
2. Make the connections according to the above pin definition.

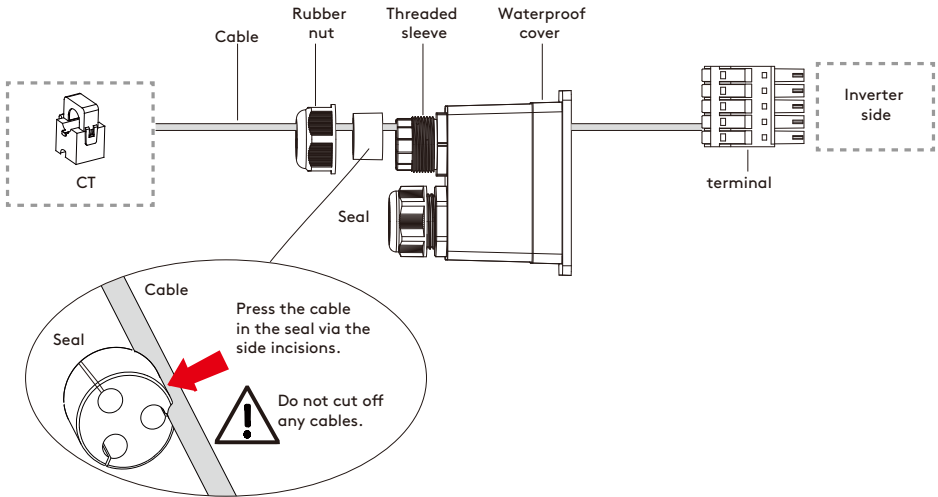

Figure 59.

### Step 3. Insert the terminal.

1. Insert the terminal into corresponding port.
2. Screw the waterproof cover back to inverter firmly with 4 x M4 screws(1.2N·m).
3. Install the seal into the threaded sleeve then fasten the rubber nut.

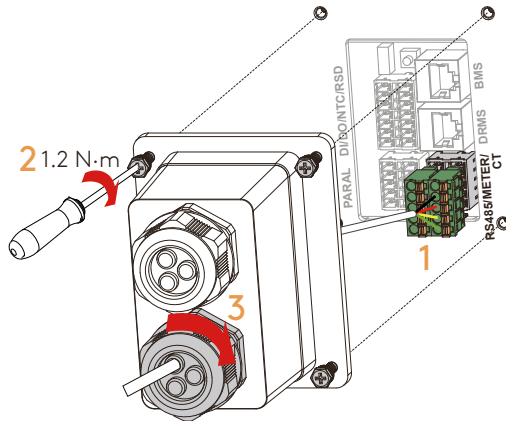

Figure 60.

## 6.6. Grid Meter Connections

### 6.6.1. Inline Meter Connection

- This solution supports CHINT-DDSU666 5(80)A meter. The meter is optional. There are two connection diagrams for the energy meter, which are shown below.

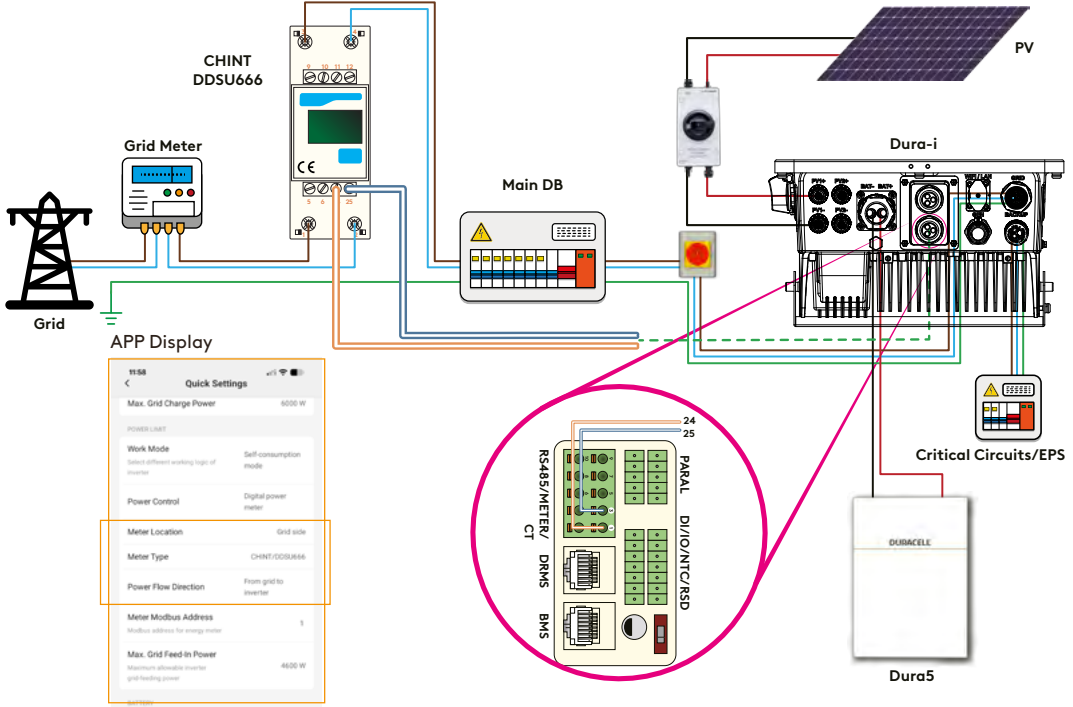

Figure 61. Grid Inline meter connection - Meter at grid side

## 6.6.2. CT + Meter Connection

This solution only supports the CHINT-DDSU666 1.5(6)A meter. The CT and meter are optional. The connection diagram for CT locating at grid side is shown as below:

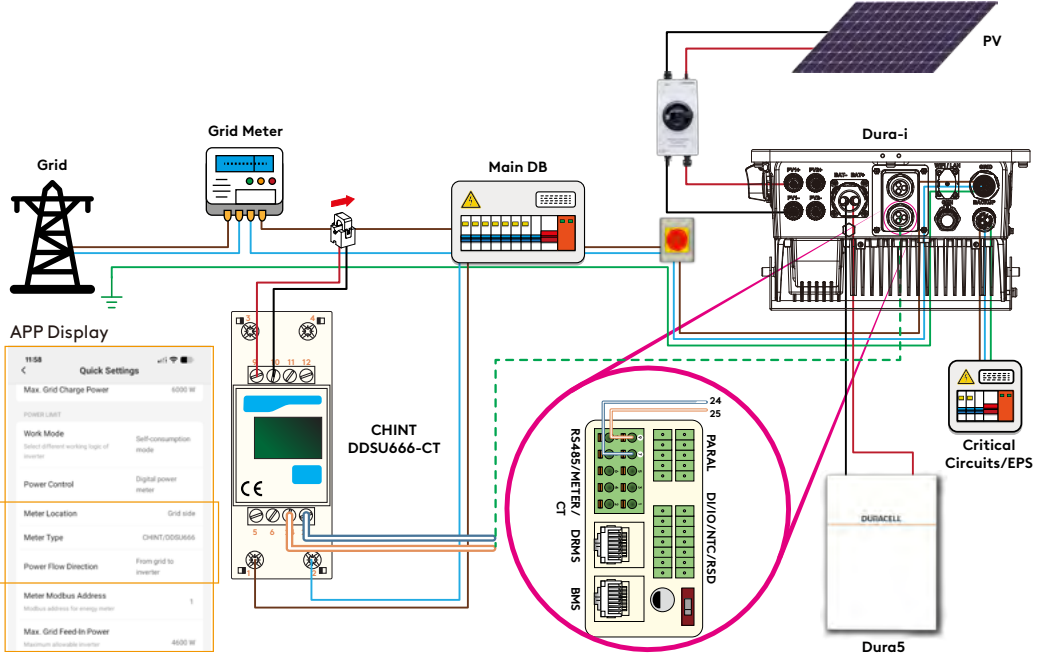
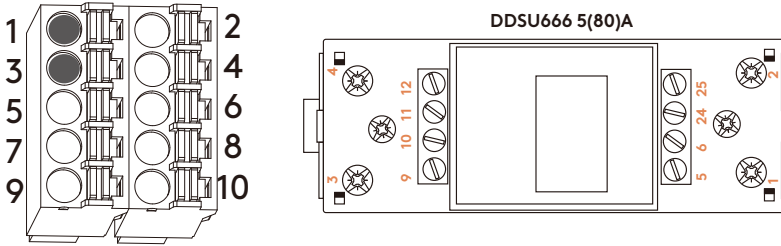

Figure 62. CT + meter

For additional information on install or function of the grid meter, please refer to its instruction manual.



Pin (Terminal)	Function Description
1	RS485_A1 (for Meter)
3	RS485_B1 (for Meter)

Pin (Meter)	Function Description
1	Grid_L
2	Grid_N
3	ESS/PV inverter_L
4	ESS/PV inverter_N
24	RS485_A
25	RS485_B

Figure 63. Pin definition of terminal

### 6.6.3. Meter Cable Connection Procedure

**Step 1.** Unscrew the waterproof cover, then loosen the rubber nut on the waterproof cover. Finally remove the sealing plugs.

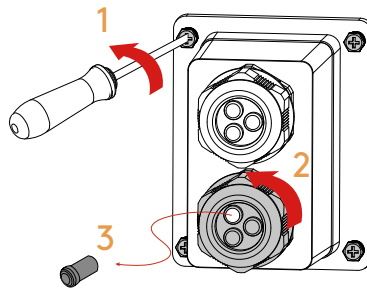

Figure 64.

**Step 2.** Thread the cables and connect them.

1. Lead the meter communication cable through the rubber nut, seal and waterproof cover in turn.
2. Make the terminal according to the above pin definition.

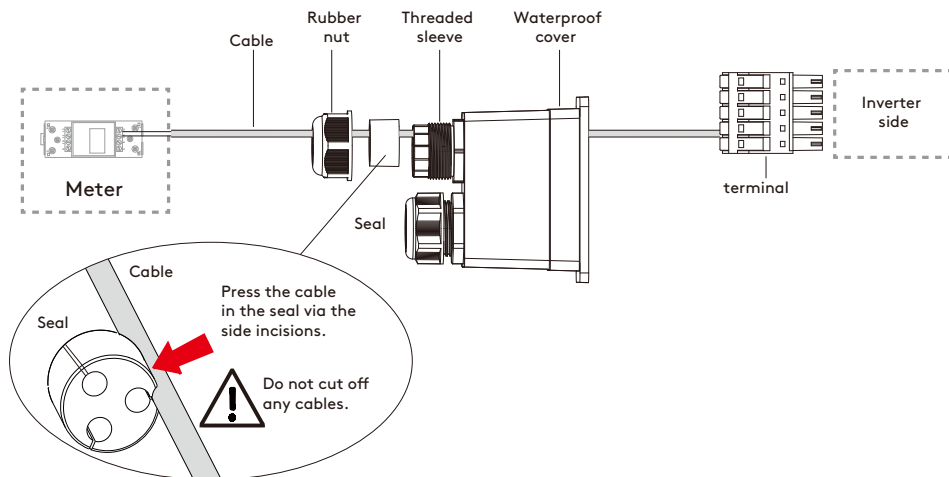

Figure 65.

### Step 3. Insert the terminal.

1. Insert the terminal into corresponding port.
2. Screw the waterproof cover back to inverter firmly with 4 x M4 screws(1.2N·m).
3. Install the seal into the threaded sleeve then fasten the rubber nut.

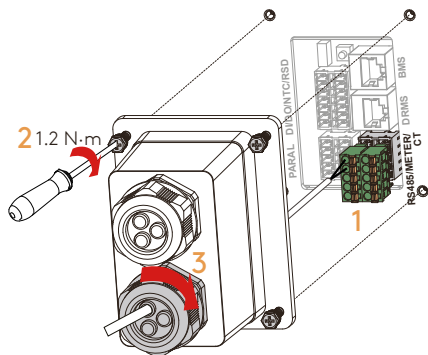
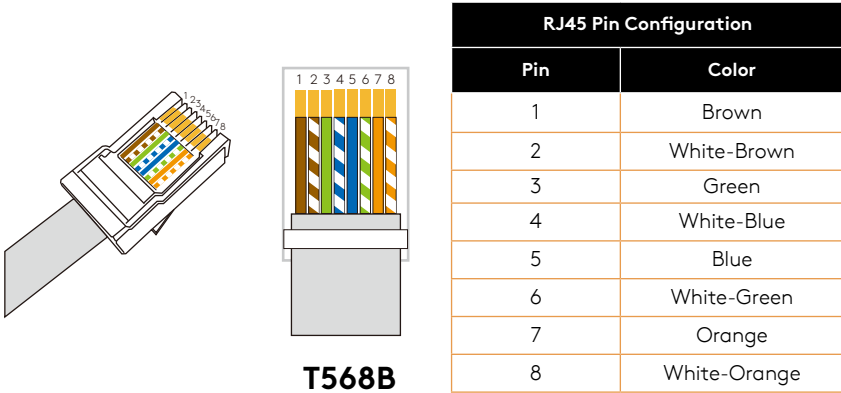

Figure 66.

## 6.7. BMS Connection for the Dura5 Battery (Inverter Side)

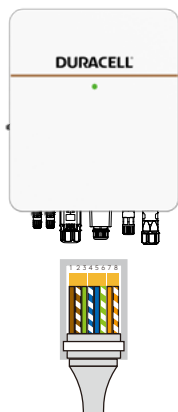

**Figure 67.** Standard RJ45 Pinout



**CAUTION**

Always face the flat side of the terminal, and count the pin slots from left to right, which correspond from 1 to 8. Read the pin definitions of both the battery and inverter carefully.



Pin (Inverter)	Function Description	Pin (Battery)	Function Description
1	RS485_ A3 (for BMS)	1	NC
2	RS485_B3 (for BMS)	2	NC
3	GND_S	3	GND_S
4	CAN_H	4	CAN_H
5	CAN_L	5	CAN_L
6	NC	6	GND_S
7	CAN_L	7	NC
8	CAN_H	8	NC

**Figure 68.** Pin definition of terminal

### 6.7.1. BMS Communication Cable Connection

**Step 1.** Unscrew the waterproof cover, then loosen the rubber nut on waterproof cover and finally remove the sealing plugs.

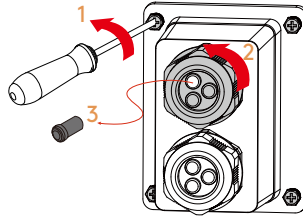

Figure 69.

**Step 2.** Lead the BMS cable through the rubber nut, seal and waterproof cover in turn.

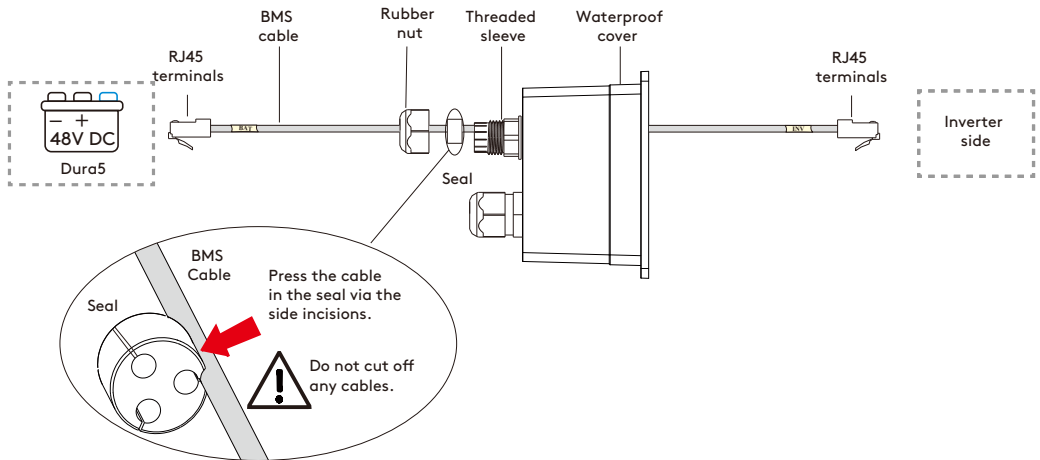

Figure 70.

**Step 3.** Insert the terminal.

1. Insert the terminal into corresponding port.
2. Screw the waterproof cover back to inverter firmly with 4 x M4 screws (1.2N·m).
3. Install the seal into the threaded sleeve then fasten the rubber nut.

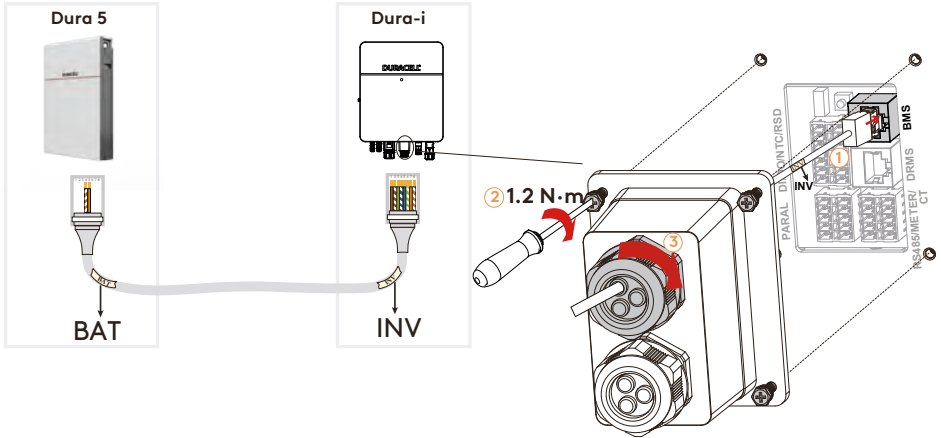

Figure 71. BMS communication cable

## 6.7.2. Parallel Communication Connection

Pin (Terminal)	Function Description	Pin (Terminal)	Function Description
1	NC	2	NC
3	GND_S	4	GND_S
5	PARA_SYNC	6	PARA_SYNC
7	CAN_L	8	CAN_L
9	CAN_H	10	CAN_H

Figure 72. Pin definition of terminal

## 6.7.3. Parallel Cable Connection Procedure

**Step 1.** Unscrew the waterproof cover, then loosen the rubber nut on the waterproof cover and finally remove the sealing plugs.

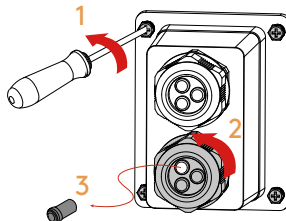

Figure 73.

### Step 2. Thread the cables and make the terminal.

1. Lead the parallel communication cable through the rubber nut, seal and waterproof cover in turn.
2. Make the terminal according to the above pin definition.

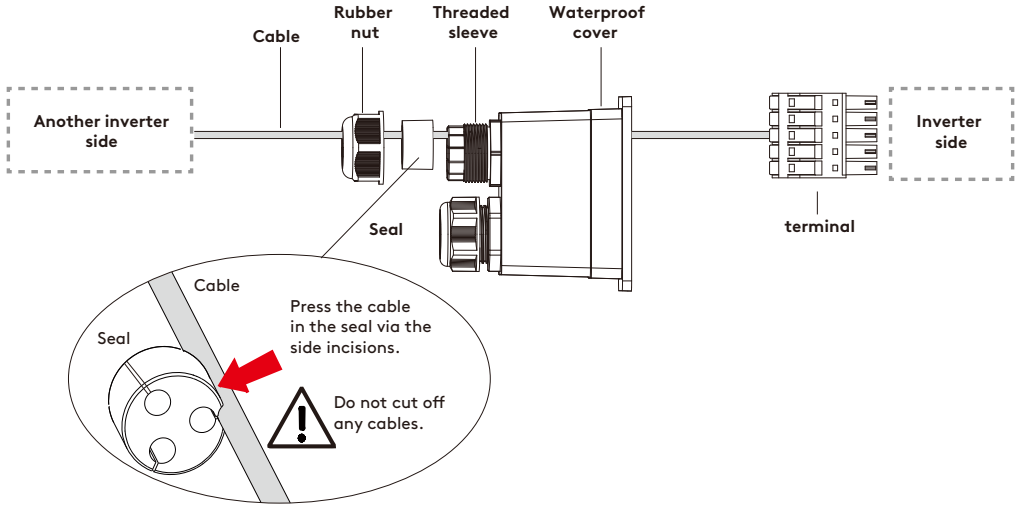

Figure 74.

### Step 3. Insert the terminal.

1. Insert the terminal into corresponding port.
2. Screw the waterproof cover back to inverter firmly with 4 x M4 screws (1.2N·m).
3. Install the seal into the threaded sleeve then fasten the rubber nut.

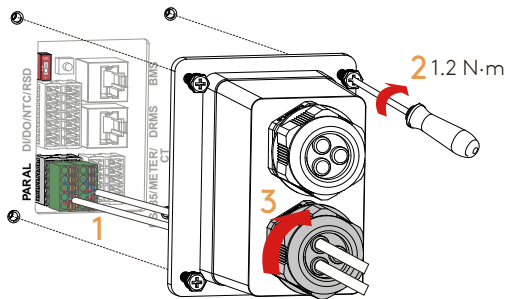
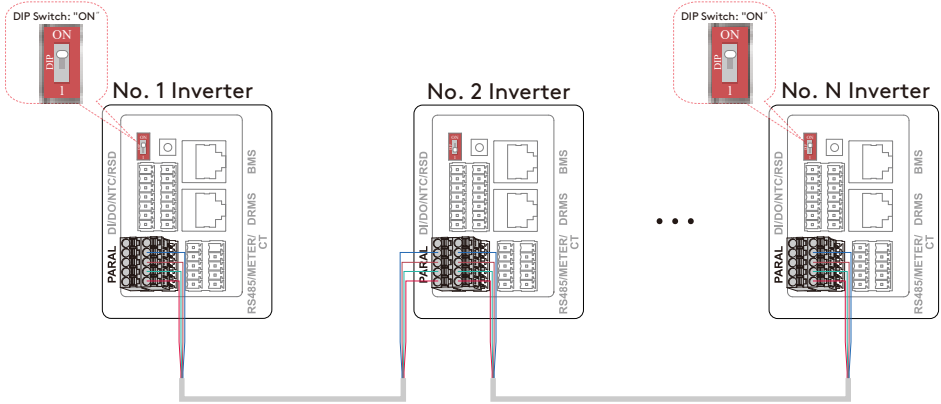

Figure 75.

**Step 4. Parallel communication cables connection between different inverters.**

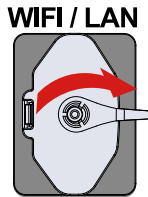

**Figure 76.** Parallel communication cables connection between different inverters.

## 6.8. Wi-Fi/LAN Dongle Connection

The dongle installation procedure:

**Step 1. Remove the cover.**



**Figure 77.**

**Step 2. Securely Insert Wi-Fi/LAN dongle into Wi-Fi/LAN port.**

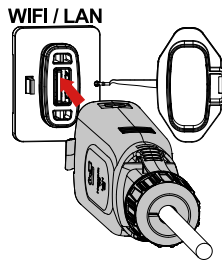

**Figure 78.** LAN Dongle

## 6.9. LAN/Wi-Fi Dongle LED status

LED	Dongle Status
Green LED	Normal Communication
Red LED	Inverter connection failure
Yellow LED	Router connection failure
Blue LED	Server connection failure
LAN LED - White	LAN connection

**Figure 79.** LAN/Wi-Fi dongle LED status



**Figure 80.**

## 7. System Operation

### 7.1. Inverter Working Mode

The inverter supports several different working modes.

#### 7.1.1. Self-consumption Mode

Go to **Setting > Inverter > Work mode** page, and select **Self-consumption mode**.

Under Self-consumption mode, the priority of PV energy consumption will be **Load > Battery > Grid**, that means the energy produced by PV gives priority to powering local loads, the excess energy is used to charge the battery and the remaining energy is fed into the grid.

This is the default mode to increase self-consumption rate. There are several situations of Self-consumption working mode based on PV energy.

##### 7.1.1.1. Normal Connection

###### a) Excess PV Energy

When there is excess PV, the PV energy will be first consumed by loads, the excess energy will be used to charge the battery and then the remaining energy will be fed into the grid.

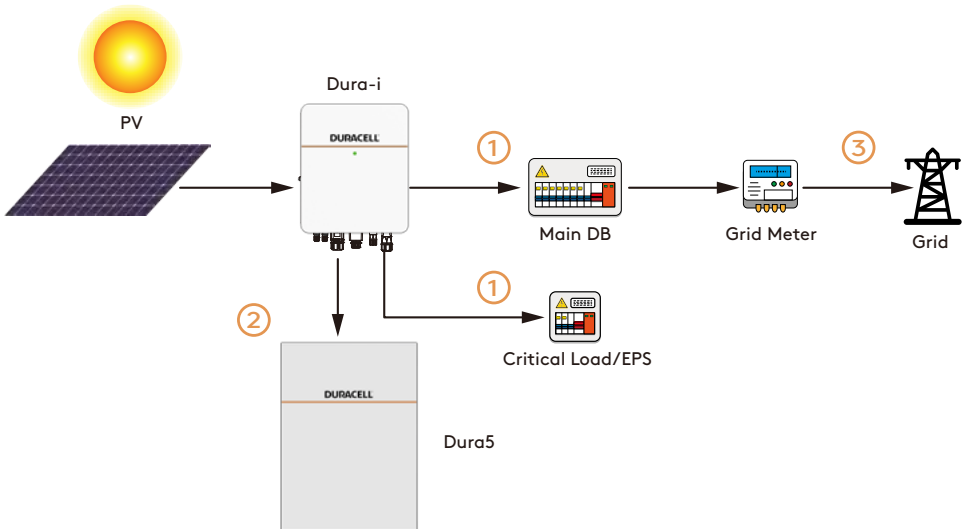

Figure 81. ① ② ③ is the sequence of PV energy transmission.

## b) Limited PV Energy

When the PV energy is not enough to cover all consumption, the PV energy will be entirely used by loads, and the remaining demand will be supplied by the battery. If the PV and battery cannot meet demand then the remainder will be supplied by the grid.

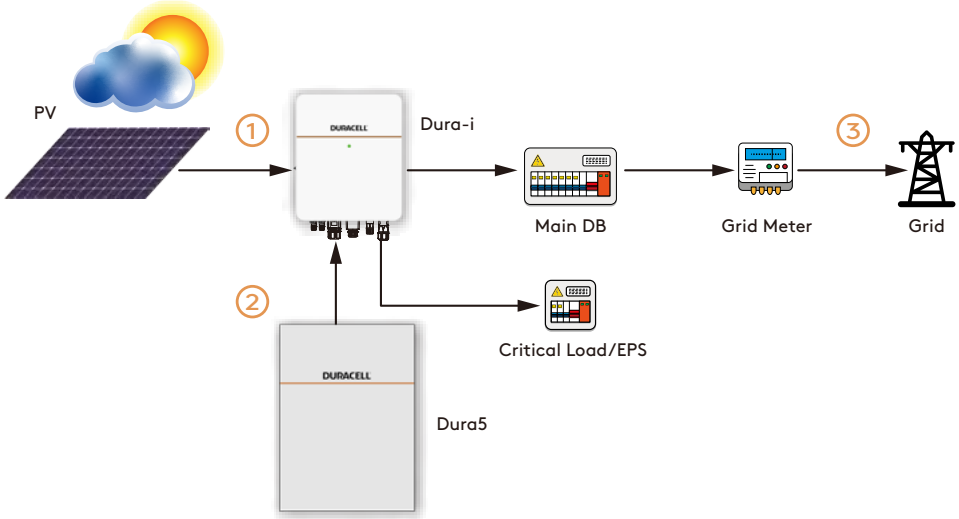

Figure 82. ① ② ③ is the sequence of load consumption

## c) No PV Input

The inverter will first discharge the battery energy for home load consumption when there is no PV input (such as in the evening or on cloudy or rainy days). If the demand is not met, the loads will consume grid energy.

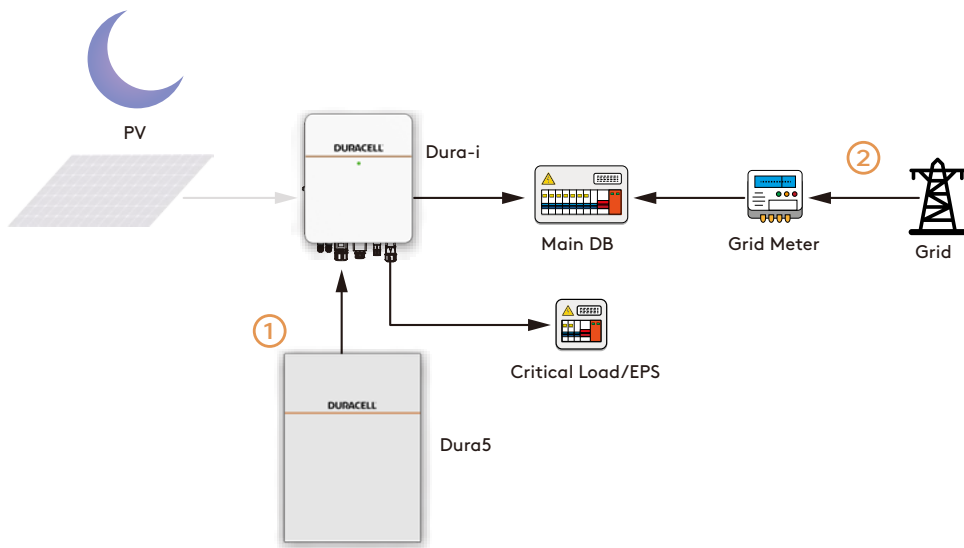

Figure 83. ① ② is the sequence of load consumption.

### 7.1.1.2. AC Coupling Connection

With AC coupling connection, PV energy generated by grid-tied PV inverters should be used to optimize self-consumption first, and any excess energy will be used to charge the batteries. If the battery is already full, excess energy could be fed into the grid. Loads are supported in priority by the grid-tied system, then by the battery power, then by the grid. The following illustrates the general distribution of PV energy.

#### a) Excess PV Energy

When there is excess PV, the PV energy will be first consumed by loads, the excess energy will be used to charge the battery and then the remaining energy will be fed into the grid.

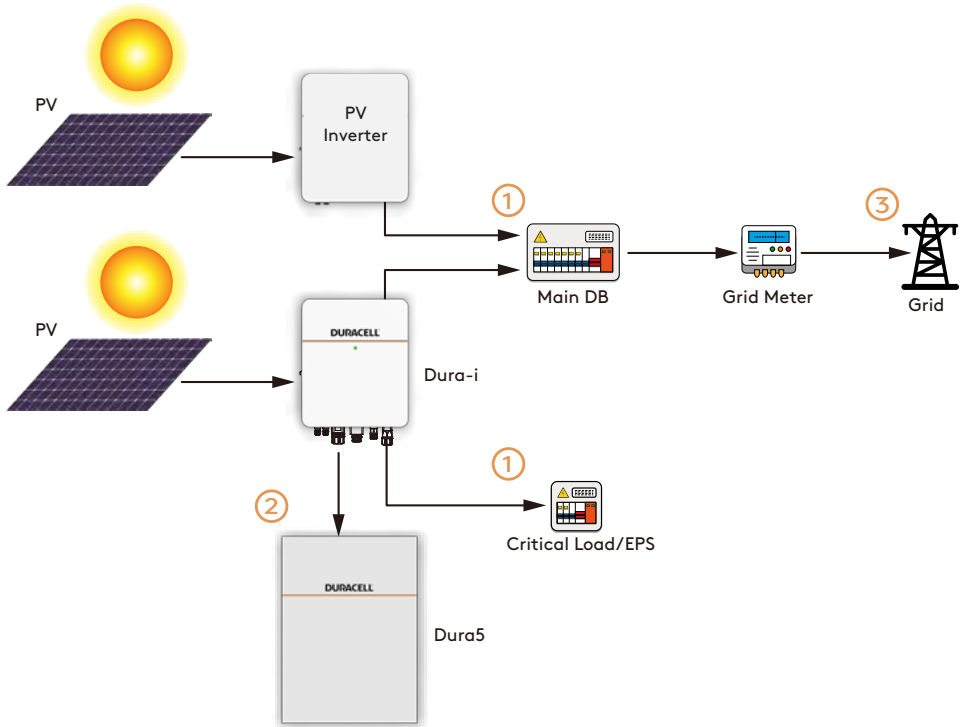

Figure 84. ① ② ③ is the sequence of PV energy transmission

## b) Limited PV Energy

When the PV energy is not enough to cover all consumption, the PV energy will be entirely used by loads, and the deficit will be supplied by battery. Any further deficits will be supplied by the grid.

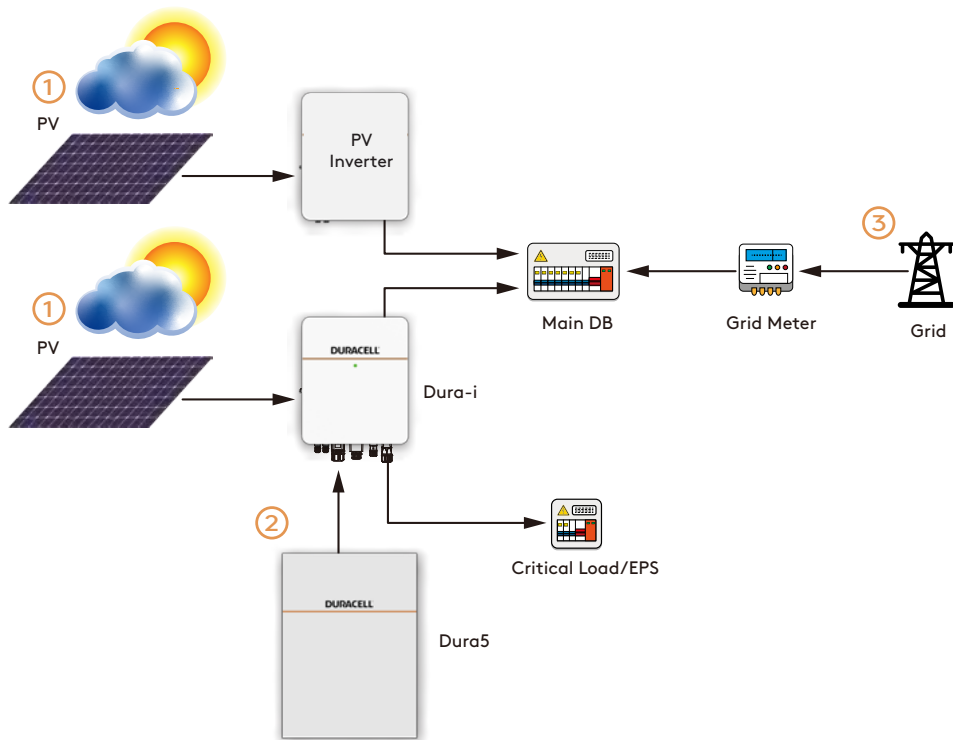

Figure 85. ① ② ③ is the sequence of load consumption

### c) No PV Input

The inverter will first discharge the battery energy for home load consuming when no PV input (such as in the evening or on cloudy or rainy days). If the demand is not met, the loads will consume grid energy.

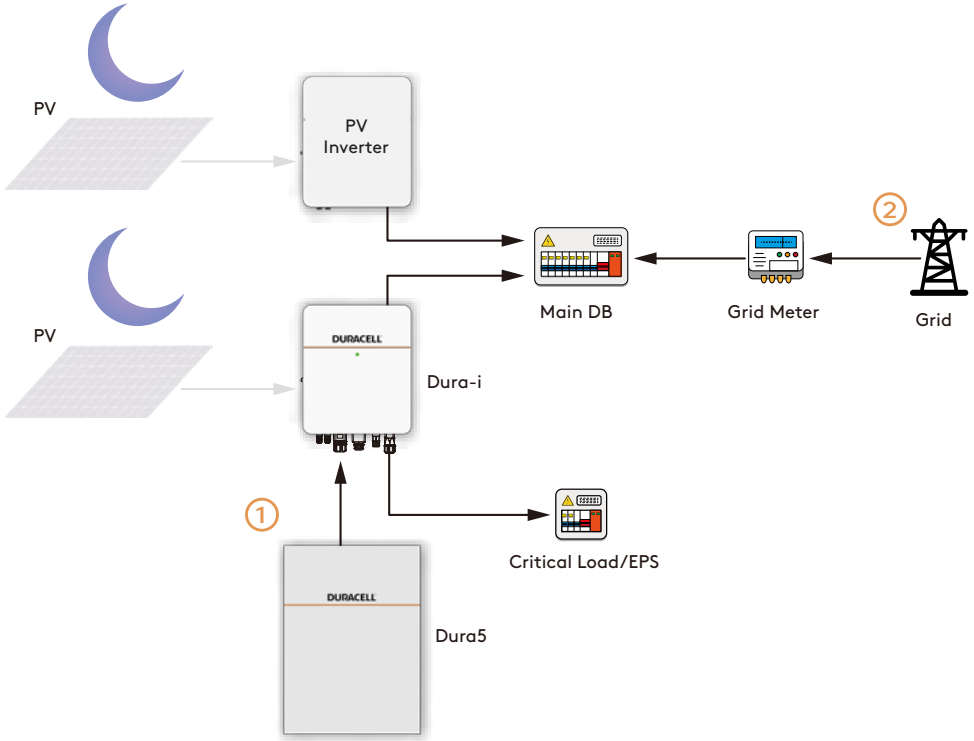

Figure 86. ① ② is the sequence of load consumption.

## 7.1.2. Feed-in Priority Mode

Go to **Setting > Inverter > Work mode** page, and select the **Feed-in priority mode**.

Under this mode, the priority of PV energy consumption will be **Load > Grid > Battery**, that means the energy produced by PV gives priority to powering local loads, the excess energy is fed into the grid, and the remaining energy is used to charge the battery.

### a) Excess PV Energy

When there is excess PV, the PV energy will be first consumed by loads. If there is excess PV energy, the power will be fed into grid. If there is still PV energy left after load consuming and grid feeding, then the remaining PV energy will be used to charge the battery.

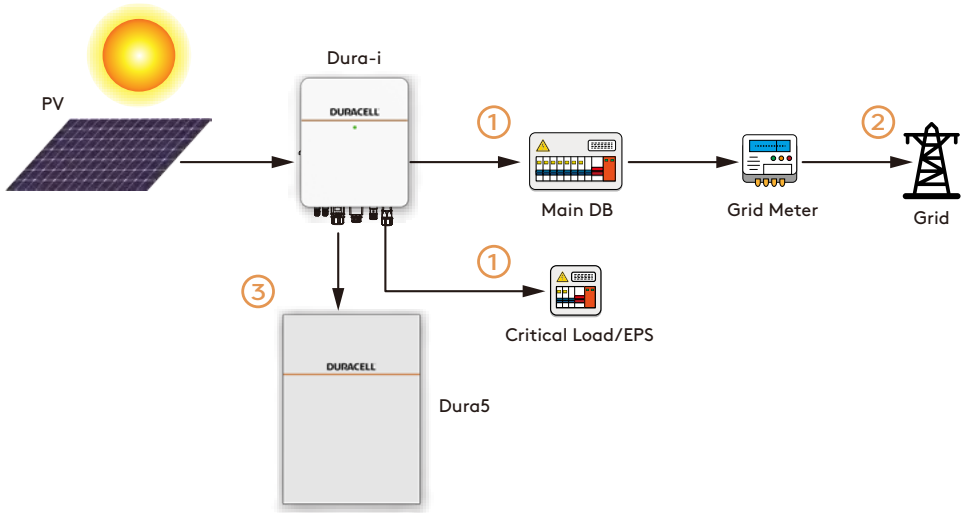

Figure 87. ① ② ③ is the sequence of PV energy transmission

## b) Limited PV Energy

When PV energy is limited and cannot meet the feed-in grid power requirement, the battery will discharge to meet it.

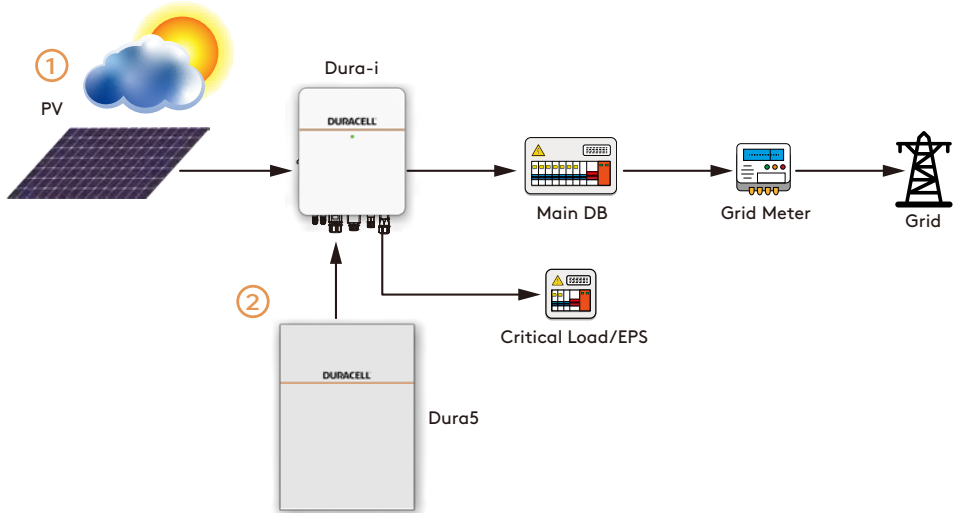

Figure 88. ① ② is the sequence of grid fed-in energy.

### c) No PV Input

The inverter will first discharge the battery energy for home load consuming when no PV input (such as in the evening or some cloudy or rainy days). If the demand is not met, the loads will consume the grid energy.

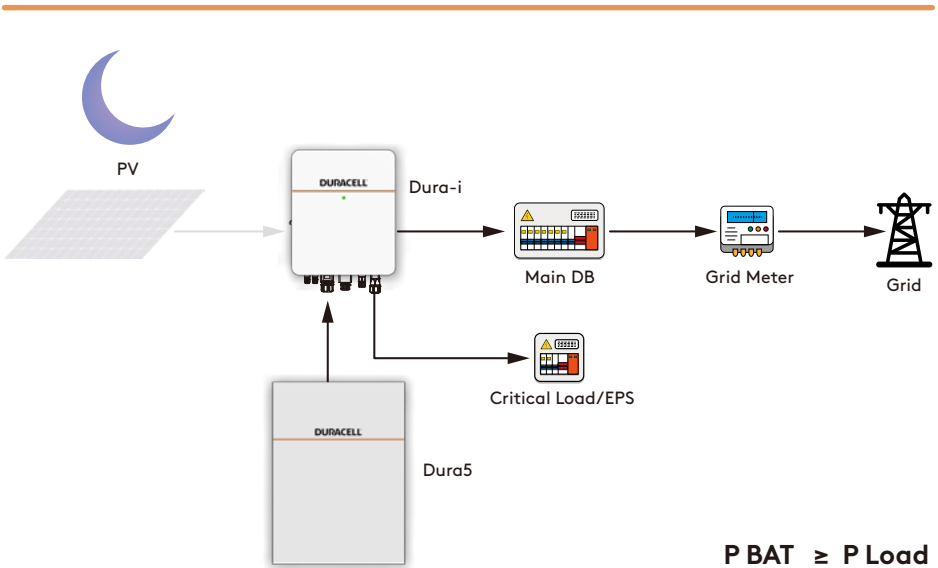
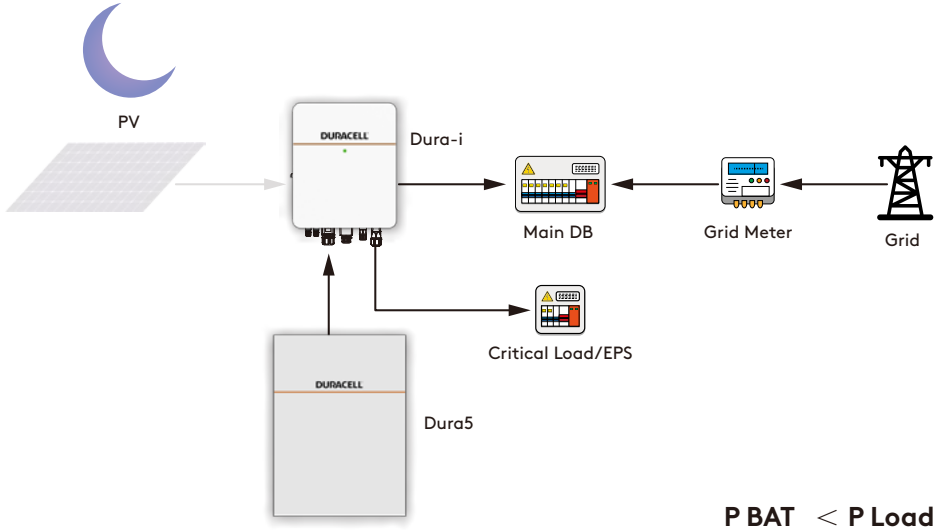

Figure 89.

## 7.1.3. BACK-UP Mode

Go to **Setting > Inverter > Work mode** page, and select the **Back-Up mode**.

Under this mode, the priority of PV energy consumption will be **Battery > Load > Grid**.

This mode aims at charging the battery quickly, and at the same time, you can choose whether to allow AC to charge the battery.

### Forbid AC charging

In this mode, the battery can be charged only with PV energy, and the charging power varies with PV energy.

#### a) Excess PV Energy

When there is excess PV, PV charges the battery first, then meets the load, and the rest is fed into the grid.

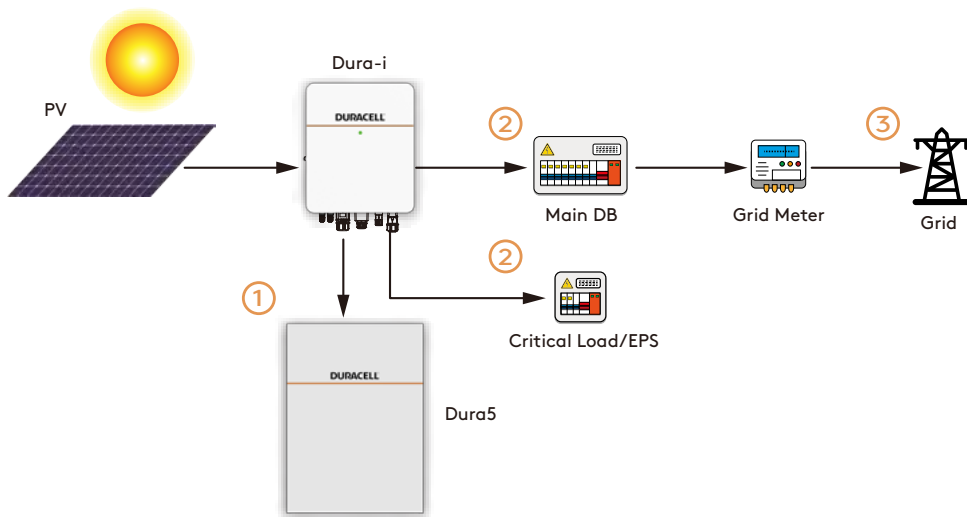

Figure 90. ① ② ③ is the sequence of PV energy transmission

## b) Limited PV energy

When PV energy is limited, PV charges the battery, and the grid meets the load demand, including normal load and BACK-UP load.

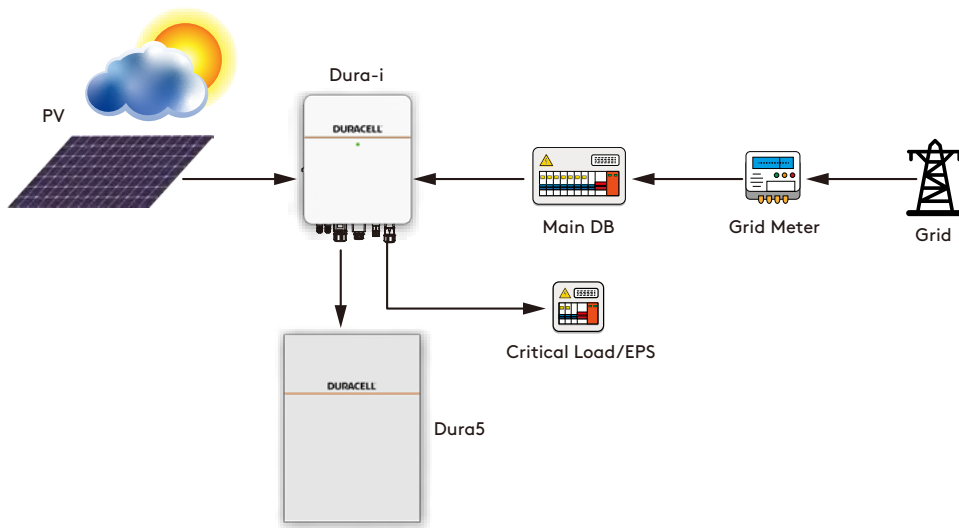

Figure 91. Limited PV energy

## Allow AC charging

In this situation, the battery can be charged both with PV and AC.

## a) Excess PV Energy

When there is excess PV, PV charges the battery first, then meets the loads, and the rest is fed into the grid.

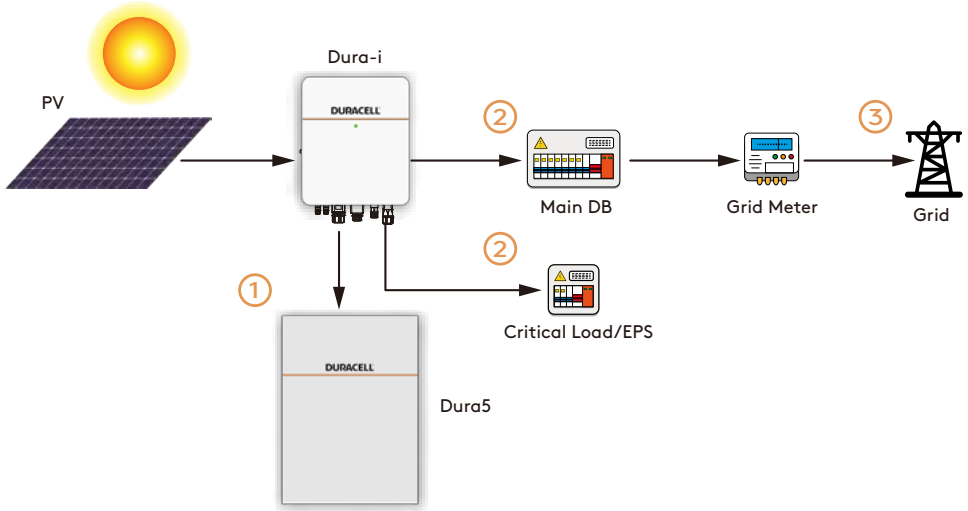

Figure 92. ① ② ③ is the sequence of PV energy transmission

### b) Limited PV energy

When PV energy is not enough to charge the battery, grid energy will charge the battery as supplement. Meanwhile, the grid energy is consumed by loads.

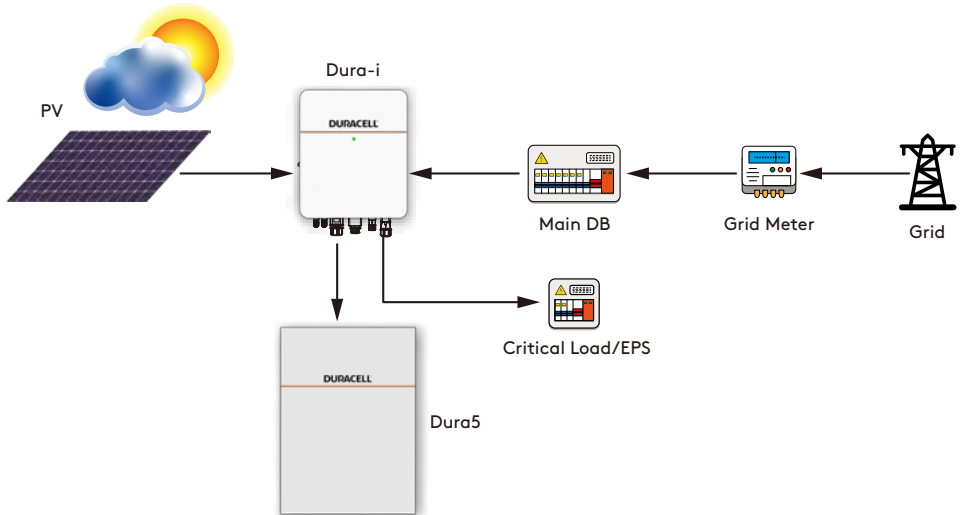

Figure 93.

## 7.1.4. Forced Charge/Discharge Function

According to the demands of application, the user can set the inverter to work on forced charge/discharge the battery in any working mode.

Please go to **Setting > Inverter > Work mode** to enable **Time-based Control** on App. There are three time periods in which you can set this function. Outside of the set periods, the inverter returns to its original working mode. The forced charge/discharge function has the highest priority. For setting details, refer to **Work mode** in the **Setting** section.

The relationship between the forced charge/discharge function and working mode shown as below.

## 7.1.5. Off-Grid Mode

When the power grid is cut off, the system automatically switches to Off-Grid mode. Under off-grid mode, only critical loads are supplied to ensure that important loads continue to work without power failure. Under this mode, the inverter can't work without the battery.

### a) Excess PV Energy

When there is excess PV, the PV energy will be first consumed by critical load, then charge the battery.

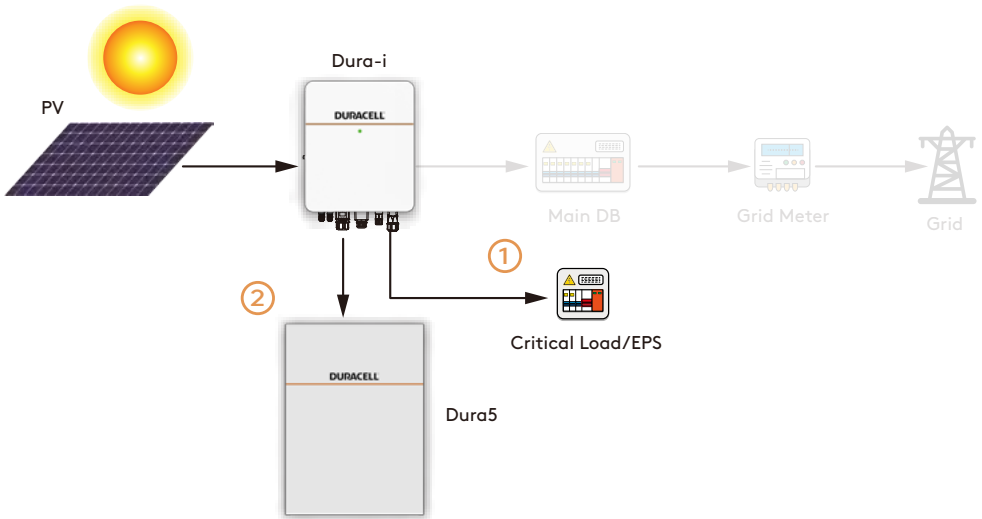

Figure 94. ① ② is the sequence of PV energy transmission.

## b) Limited PV energy

When PV energy is limited, BACK-UP loads are first powered by PV and then supplemented by battery.



### NOTICE

- Under this mode, please complete the output voltage and frequency settings.
- It is better to choose the battery capacity larger than 100Ah to ensure BACK-UP function works normally.
- If BACK-UP output loads are inductive or capacitive loads, to make sure the stability and reliability of system, it is recommended to configure the power of these loads to be within 50% BACK-UP output power range.

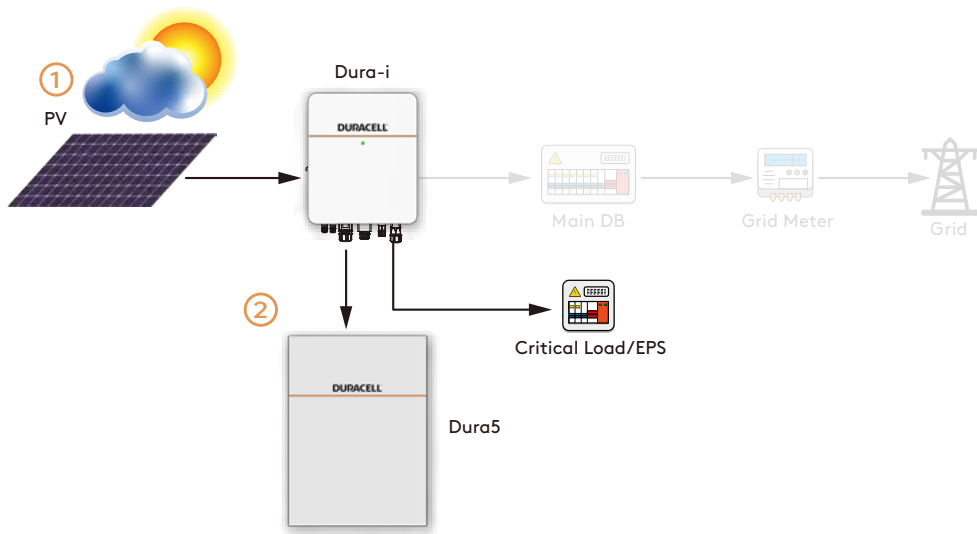

Figure 95. ① ② is the sequence of BACK-UP load consumption.

## 8. Startup & Shutdown Procedures

### 8.1. Inspection

No.	Items
1	The inverter is firmly installed on the wall.
2	There is enough heat dissipation space, no external objects or parts left on the inverter.
3	Positioning is convenient for operation and maintenance.
4	The wiring of the system is correct and firmly in place.
5	Check whether the DC and AC connections are correct with a multimeter, and ensure there is no short circuit, break, or incorrect connections.
6	Check whether the waterproof nuts of each part are tightened.
7	The vacant ports have been sealed. All gaps at the cable inlet and outlet holes have been plugged with fireproof/waterproof materials, such as fireproof mud.
8	All safety labels and warning labels on the inverter are complete and without occlusion or alteration.
9	<p>Confirm the parameters and configurations conform to relevant requirements.</p> <ul style="list-style-type: none"> <li>■ AC Frequency: 50 ± 0.5Hz</li> <li>■ PV Voltage: 70 V DC to 550 V DC</li> <li>■ Battery Voltage: 40 V DC to 65 V DC</li> <li>■ Grid AC Voltage: 216 V AC to 253 V AC</li> </ul>

### 8.2. Startup Procedure

Make sure all the above points are checked and correct, then follow the procedure to start up the inverter:

1. Power on PV.
2. Power on the Battery.
3. Power on the AC.
4. Power on the BACK-UP.
5. Turn on the inverter. For the first startup, refer to the Startup Guide to complete Quick Setup in the App and tap the Power-on icon to turn on the inverter. For any non-first-time startup, press and hold the ON/OFF button on the side of the inverter for five seconds to turn it on. Refer to **Figure 96 on p70**.

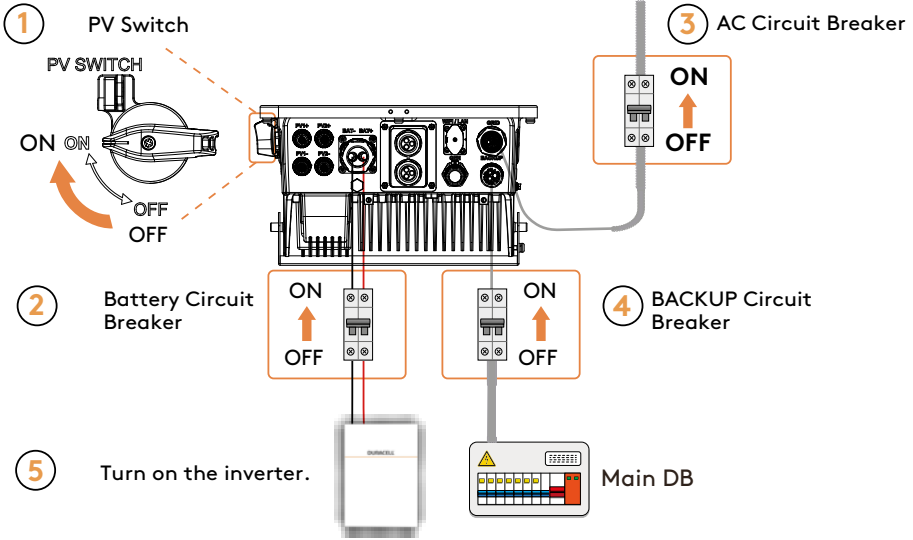

The first time:  
Refer to the manual and complete Quick Settings on the LCD or Quick Setup on the app. Then tap the power-on icon.



Other times:  
Press the button (5s).

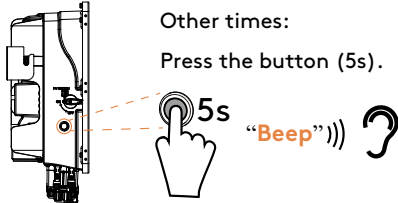

Figure 96.

## 8.3. Shutdown Procedure

If there is a requirement to shut down the system, please follow the procedure below:

1. Turn off the inverter. Tap the Power-off icon on the LCD home screen or App Quick Setup page to turn off the inverter. Or you can press and hold the ON/OFF button on the side of the inverter for five seconds to turn it off.
2. Power off the BACK-UP.
3. Power off the AC.
4. Power off the Battery.
5. Power off the PV.
6. If you need to disconnect the inverter cables, please wait at least 10 minutes before touching these parts of the inverter.



**DANGER**

Even after the inverter is powered off, the remaining electricity and heat may still cause electric shock and burns. If need to disconnect the inverter cables, please wait at least 10 minutes before touching these parts of the inverter.

### 1 Turn off the inverter.

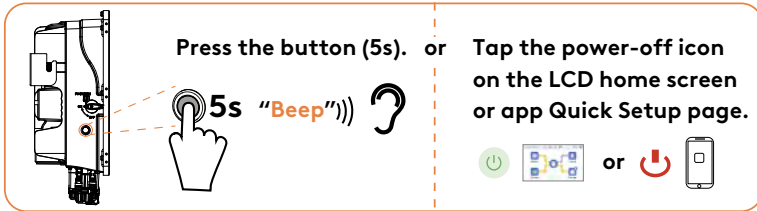

### 5 PV Switch

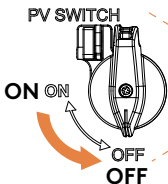

### 4 Battery Circuit Breaker

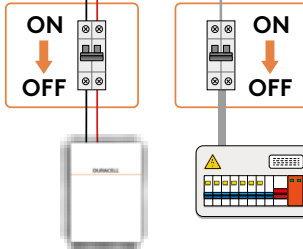

### 3 AC Circuit Breaker

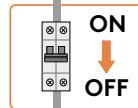

### 2 BACKUP Circuit Breaker

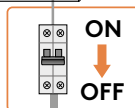

Main DB

Figure 97.

## 9. Commissioning

### 9.1. Commissioning Process

Scan the following QR code to download the Dura-i app.

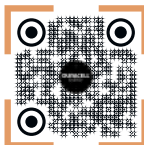
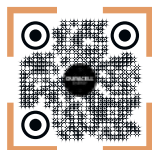

1. Log into the Service Account provided.

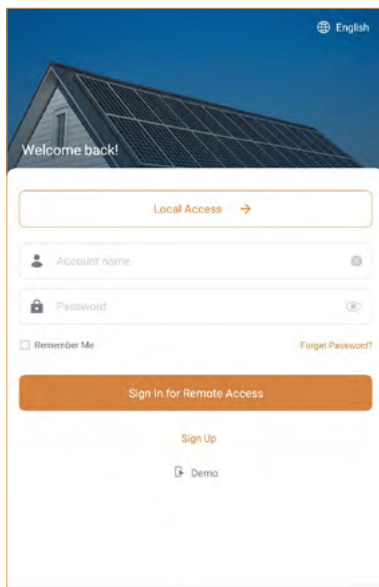

**Figure 98.**



NOTE

If you do not have login credentials, contact [sales.uk@duracellenergy.co.uk](mailto:sales.uk@duracellenergy.co.uk) or call **01386 577845**.

## 9.1.1. Access Account Management

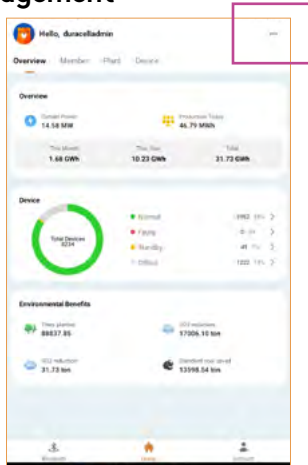

Figure 99.

Tap on the '...' (meatballs) in the top right.  
This section shows all your previous plants and installations.

## 9.1.2. Start New Commissioning

1. Tap on **+ Start New Commission**.

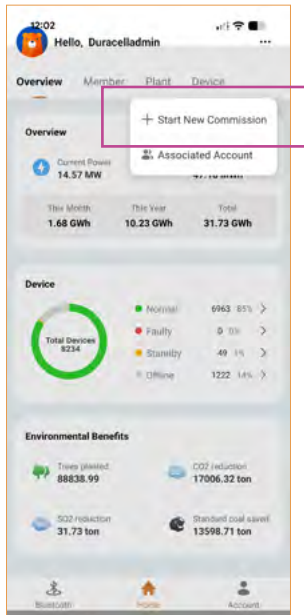

Figure 100.

## 9.1.3. Create Plant & Add Inverter

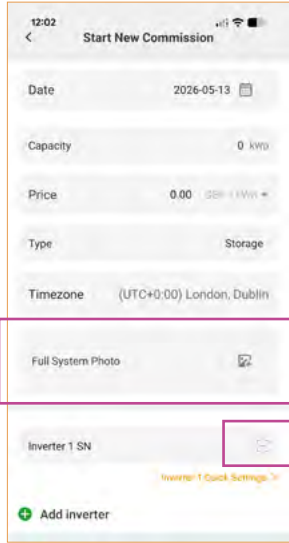

Figure 101.

1. Fill in the plant-specific details and add a full system photo.
2. Scan or input the inverter serial number.

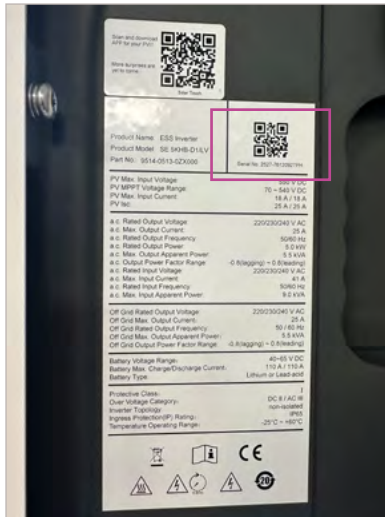

Figure 102.



NOTE

**For parallel installations, select the correct number of inverters and scan/input all of their serial numbers.** The first inverter serial number entered will act as the primary.



NOTE

For parallel installations, follow the **Parallel Install Guide** found at this link.

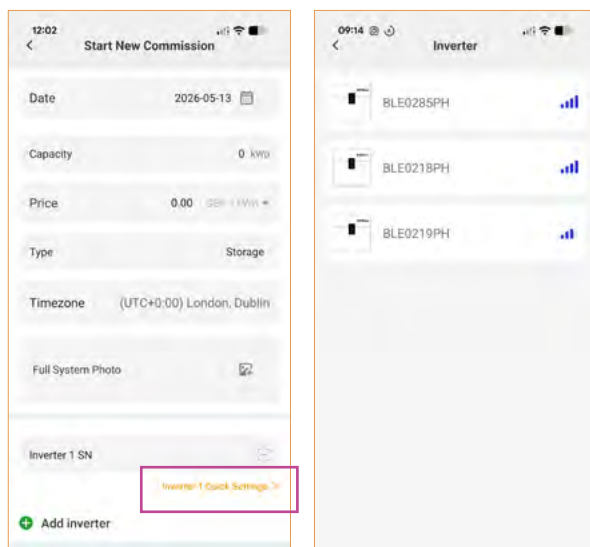

**Figure 103.**

3. Tap on **Inverter Quick Settings**

## 9.2. Complete Quick Setup

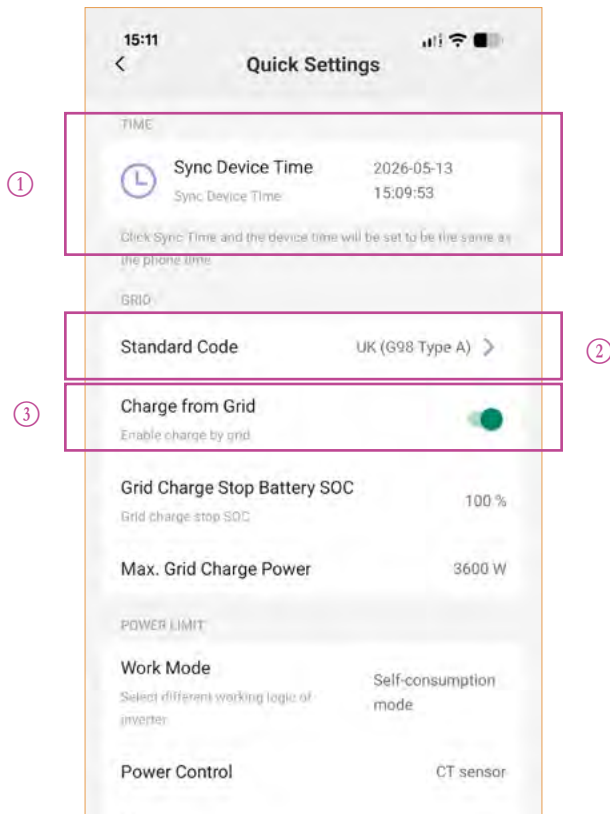

Figure 104.

**Step 1.** Synchronize the inverter's Wi-Fi by tapping **Sync Device Time**.

**Step 2.** Select your grid's **Standard Code**.

**Step 3.** Enable **Charge from Grid**.

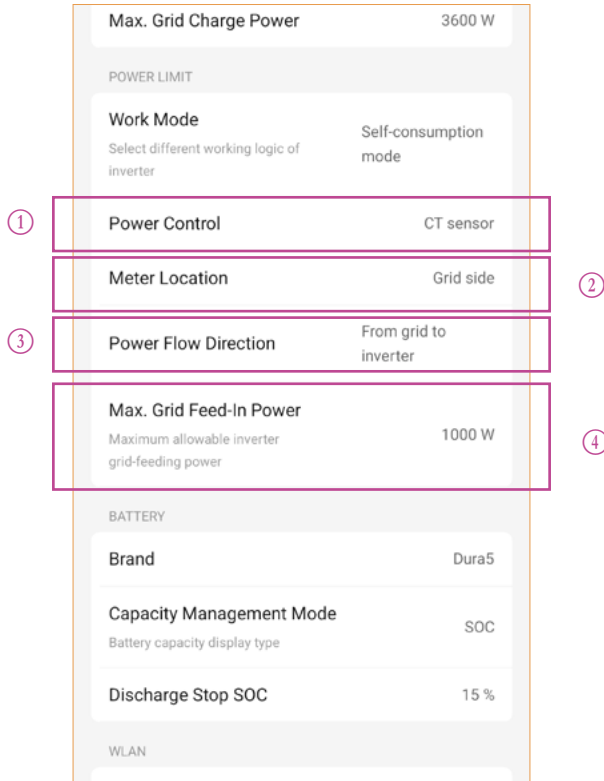

Figure 105.

#### Step 4. Power control parameters

In this step you will set how the inverter reads grid and house load.

1. For **"Power control"** select **"CT Sensor"**, unless using an REM select **"Digital Power Meter"**.
2. For **"Meter location"** select the location you have chosen (from **Figure 13 on p17**, inline meter **Figure 61 on p44** and CT+ meter **Figure 62 on p45**). For standard installation it is recommended to install the CT on the incoming grid live cable before the main house distribution board as shown in **Figure 12 on p16**.
3. For **"Power flow direction"** select the direction in which the arrow on the CT sensor is pointing. For standard installation it is recommended to install the CT pointing from the grid to inverter as shown in **Figure 12 on p16**.
4. For **"Maximum feed in grid power"**, this should be set to the size limitation of the inverter OR the maximum allowed by the DNO as grid standard, whichever is lower.

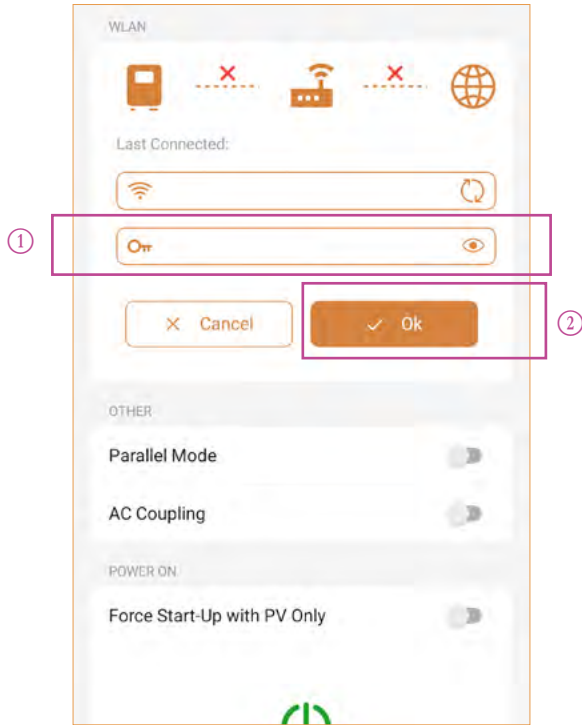

Figure 106.

### Step 5. Configure the internet connection

The name of the Wi-Fi network your phone is connected to should prepopulate. Enter your Wi-Fi password.

### Step 6. Tap on Ok

If the configuration was successful, the indicator light on the Wi-Fi / LAN dongle will change colour from Orange to Flashing Blue and then to Green.

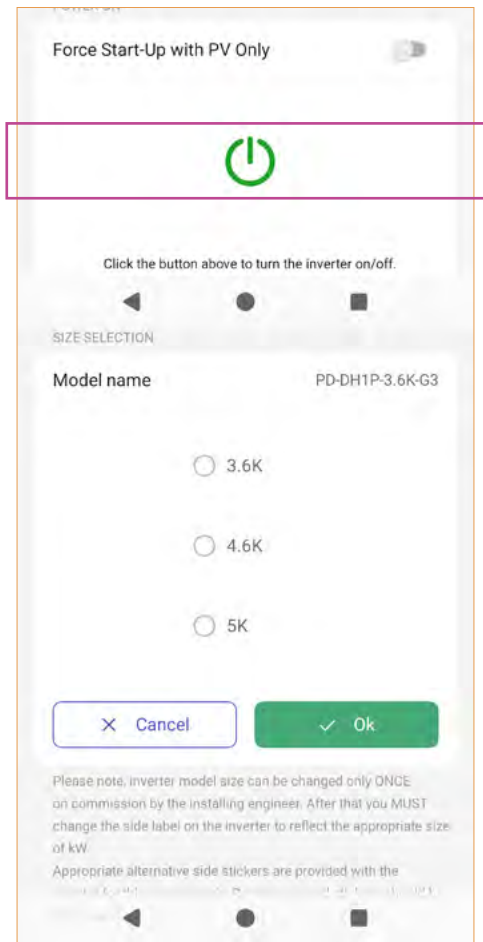

Figure 107.

**Step 7.** In this step, please click the power button to turn on the inverter.

**Step 8.** If you need to change the size of the inverter, select the relevant size and press **Ok**.



NOTE

Inverter model size can be changed only ONCE on commission by the installing engineer. After that you MUST change the side label on the inverter to reflect the appropriate size of KW.



NOTE

You must seek approval from the local DNO before changing export limits.

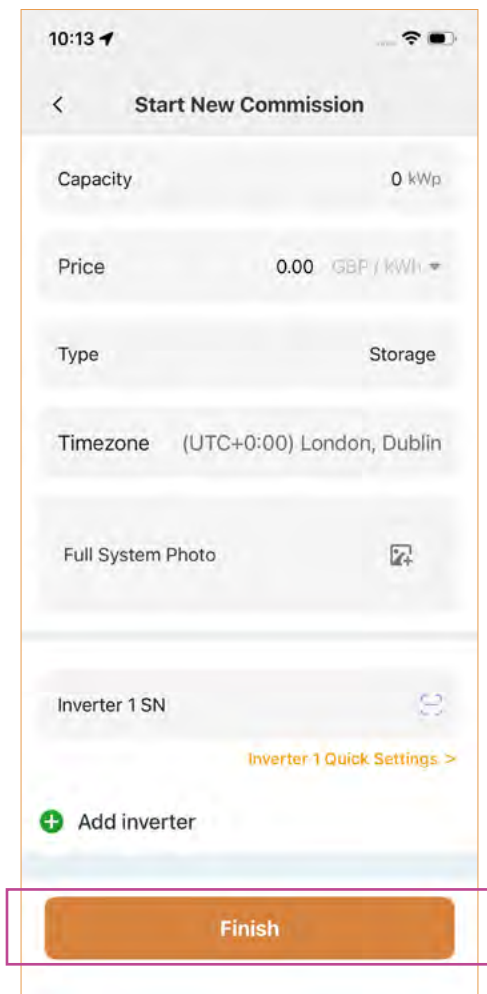

**Figure 108.**

Once all Quick Settings are complete, return to the Plant Creation page, and tap on '**Finish**' this will add the inverter to your plant list on your Dura-i account.

## 10. Linking the Plant to the Consumer's App

Establishing a customer plant connects the inverter to the internet, enabling the customer to view data online. Additionally, it allows the installer and Duracell Energy to remotely access the data, and make setting adjustments. Please make the customer aware of our **Consumer App Guide** which they can download from our website.

Follow the steps below to create the customer an account:

### 10.1. Download the Duracell Energy App

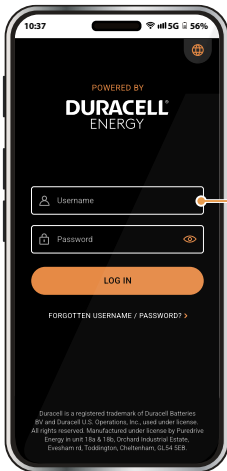
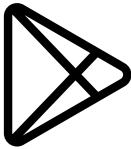

Enter your installer  
Username  
and Password

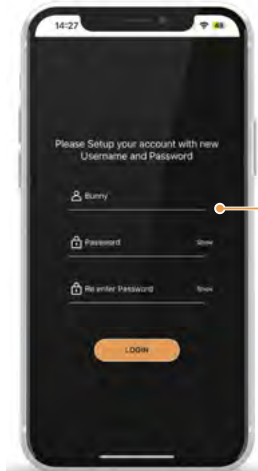

If you do not have a  
Username & Password  
then please email  
**support.uk@duracellenergy.com**  
or call **01386 577845**

Figure 109.

To register an EV Charger, please select this

To run a two-minute battery test, please select this

This is where you'll find your previous installations

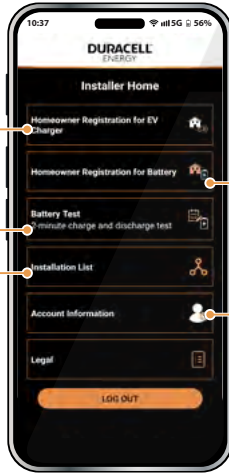

To register a battery **or an inverter** please select this

This option is for your installer account details

Figure 110.

## 10.2. Battery/Inverter ID Registration

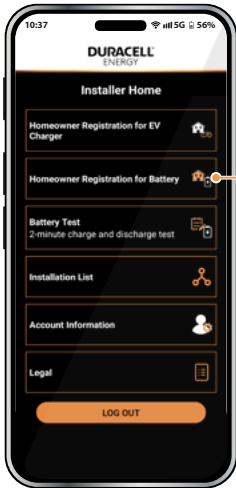

Select homeowner registration from options

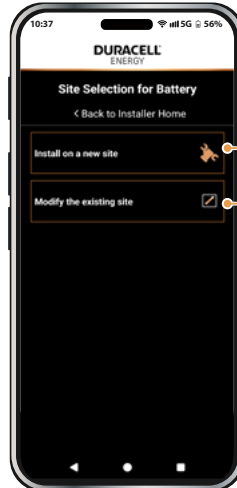

To register a battery to a new user

To register a battery to an existing user

Figure 111.

## 10.3. Install at a New Site

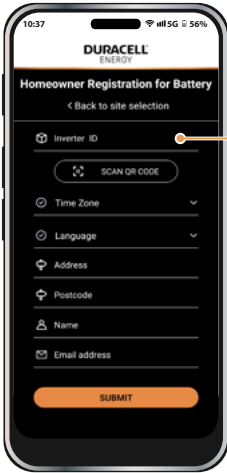

DC Product - Enter Dura-i inverter serial number

AC Product - enter APP ID

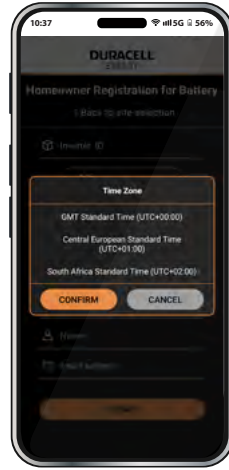

Select Time Zone

Figure 112.

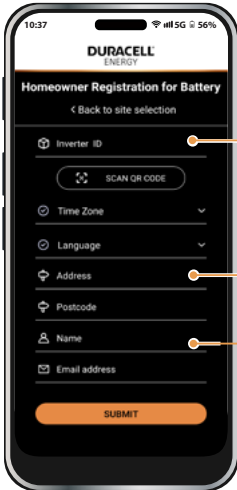

Enter these details CAREFULLY as you may need them to search for the installation in the future. After filling this in select 'submit'. This sends an automated email with temporary login credentials to the homeowner.

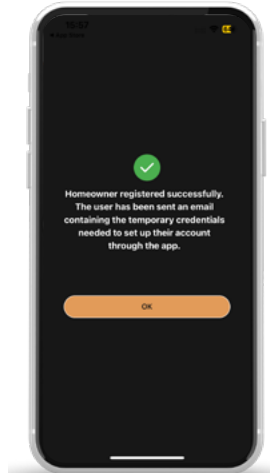

Using those credentials, the homeowner can place their own passwords and use the app to monitor and control their system

Figure 113.

## 10.4. Modify the Existing Site

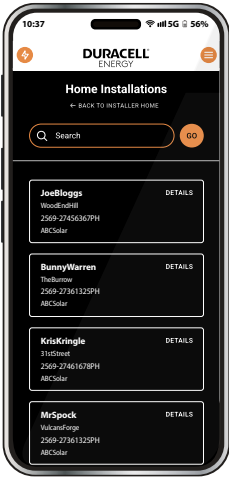

For an existing homeowner, search the Duracell Energy battery's Inverter ID and the homeowner's name should pop up

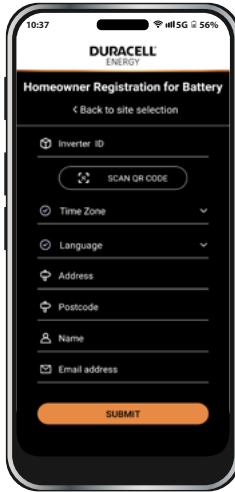

Select the customer and fill the necessary details in the registration page

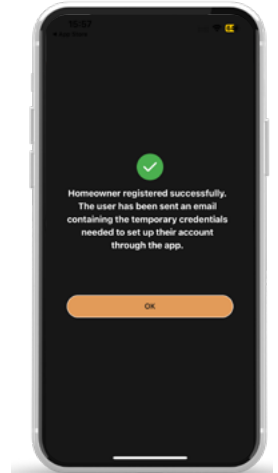

After filling this in select 'submit'. This sends an automated email with temporary login credentials to the homeowner

Figure 114.

## 10.5. Homeowner Initial Login

Homeowner receives an automated email

Go to the main login page and enter temporary username and password

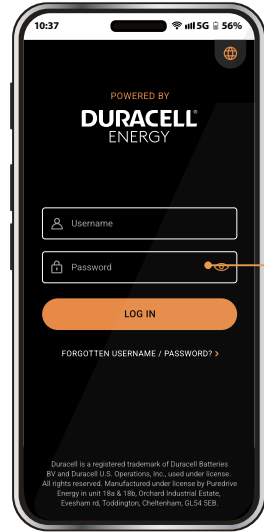

Homeowner enters temporary username and password

Figure 115.

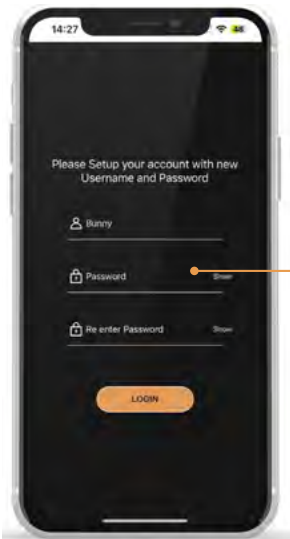

Homeowner chooses own password

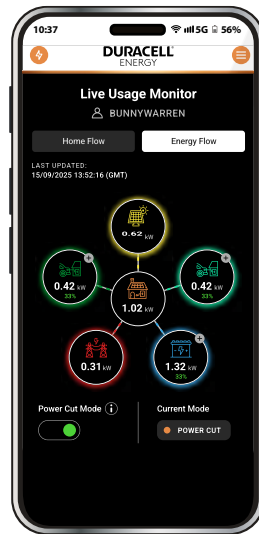

Check live usage monitor page

Figure 116.

## 11. Generator Installation Guide



**NOTE** THIS IS FOR AUTOMATIC START UP ONLY!

### 11.1. Generator Use

A generator can be used to help cover critical circuits and to charge the batteries in the event of a power cut.



**NOTE** This will not cover full house BACK-UP (ATS).



**NOTE** It is recommended that the generator chosen is at least 1.5x the kW capacity of the inverter.



**NOTE** The changeover switch in **Figure 117** is not mandatory but is strongly recommended for ease of future maintenance.

### 11.2. Connections

#### 11.2.1. Generator Power Layout

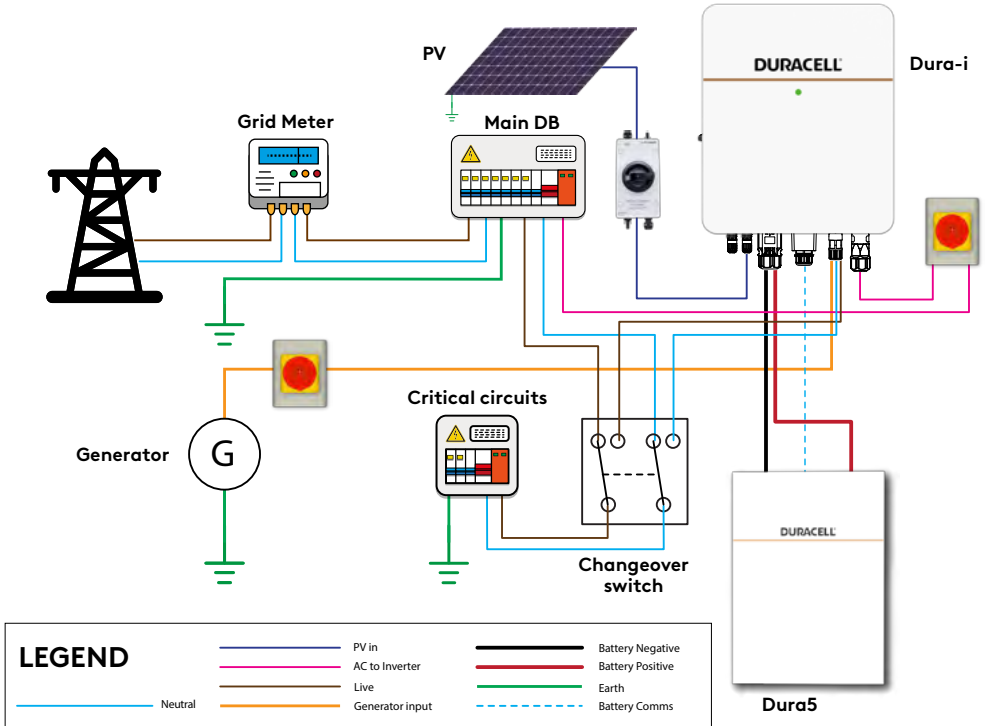

**Figure 117.** Generator Power layout

## 11.2.2. Generator Comms Layout

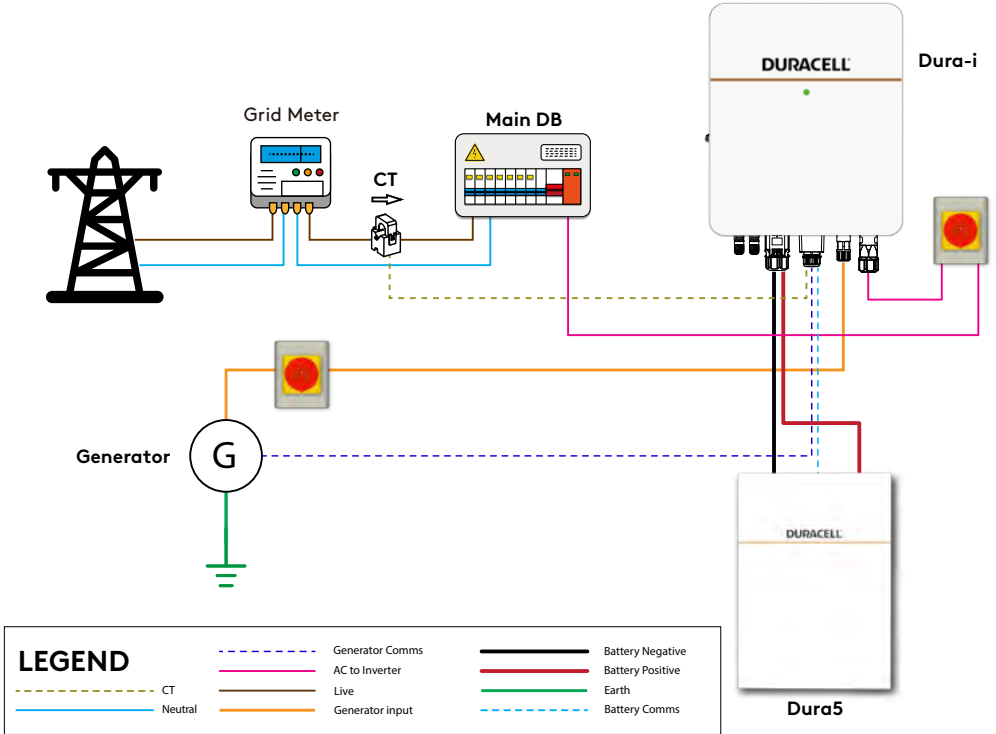

**Figure 118.** Generator Comms layout

For automatic start function you must use the automatic switch within the inverter, and a generator with auto-start capability (two wire). This connects into ports 13 and 14 on the 14-port green terminator that is packaged with the Dura-i. See **Figure 119**.

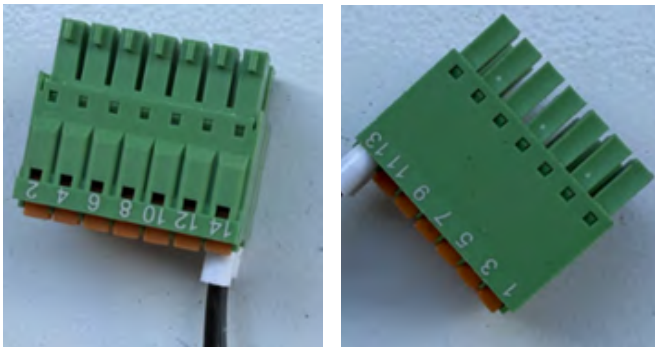

**Figure 119.**

This 14-port terminator plugs into the comms port on the inverter/under the glanded section highlighted in **Figure 120, Point 4.**

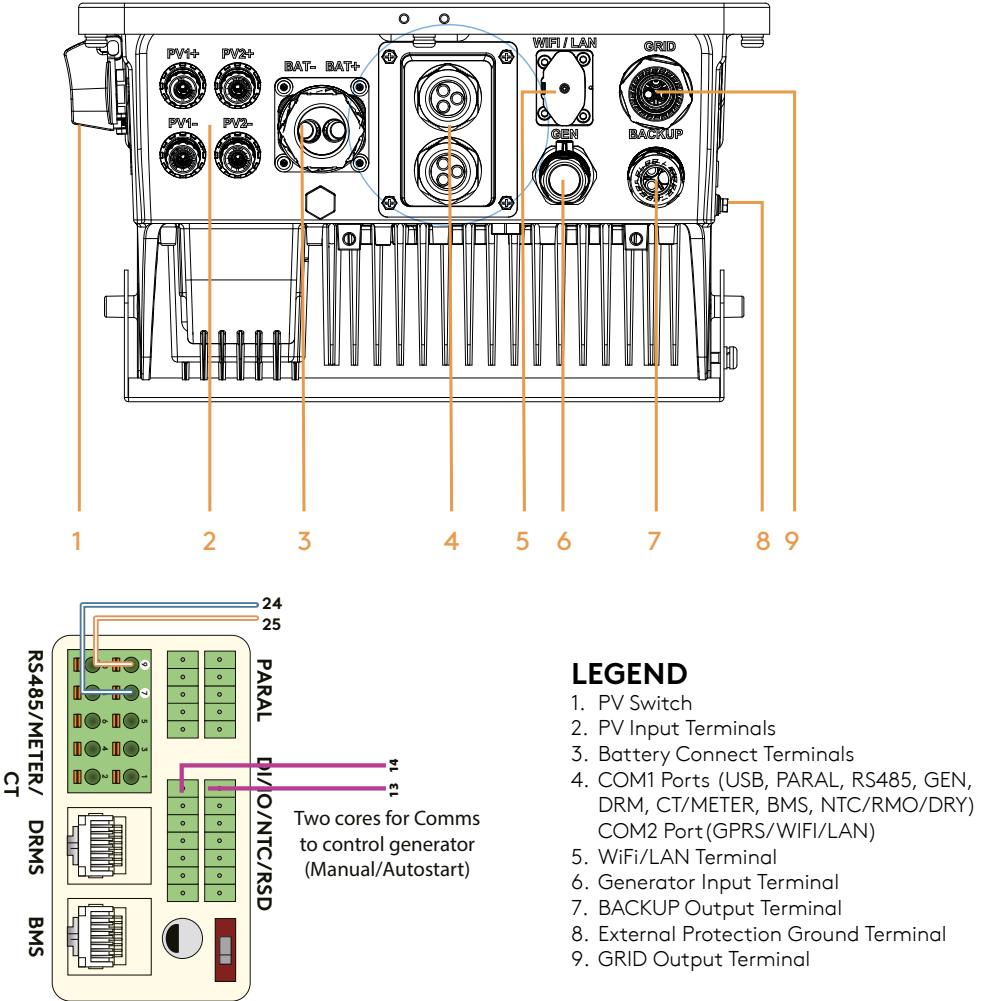

**Figure 120.**

An autostart-enabled generator would normally be supplied with an ATS adaptor. This must be the type with a start/stop function and should have two cores to connect into the inverter.

## 11.3. Adding a Generator on the Dura-i App.

Follow the commissioning process, [9.1. Commissioning Process \(p72\)](#).

**Step 1.** Once final step is completed go to the settings page.

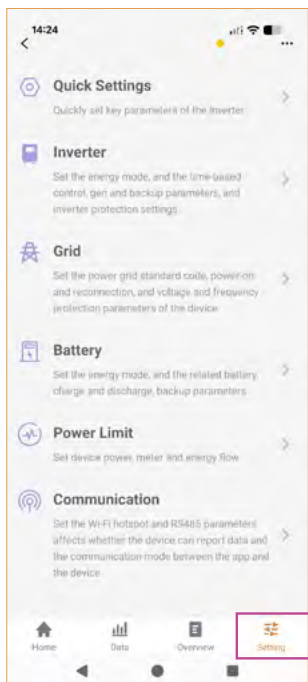

Figure 121.

## Step 2. Tap on Inverter

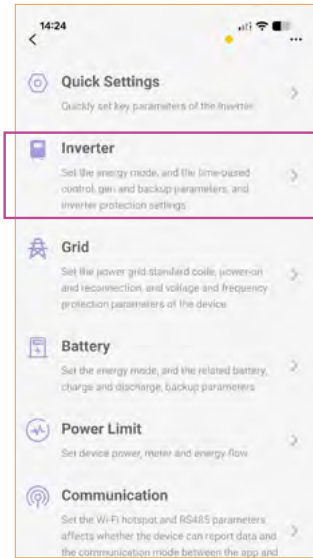

Figure 122.

## Step 3. Tap on Gen

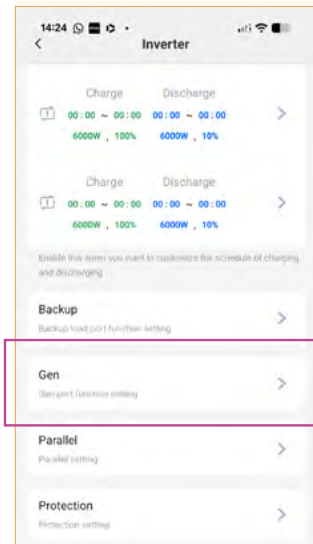

Figure 123.

## Step 4. Select Generator.

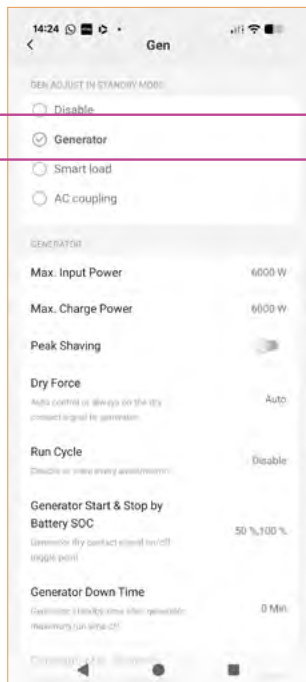

Figure 124.

All the generator settings will then populate.

**Step 5. Ensure the Generator Start State of Charge (SOC) is set to 18%.**

Generator Stop SOC is optional. We would recommend 85% or higher.  
(This is the maximum SOC of the battery before the generator shuts off).

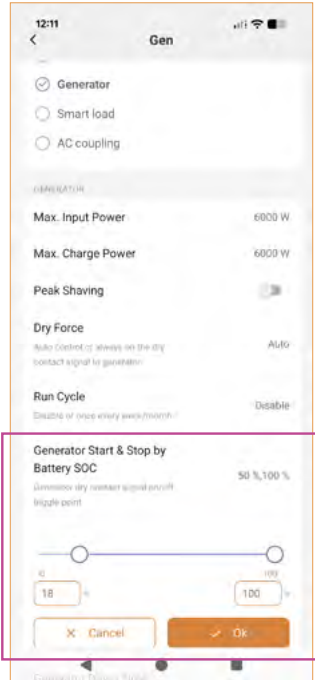
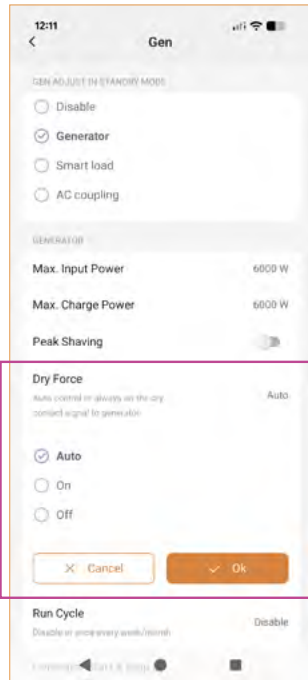

Figure 125.

**Step 6. Dry Force must be selected as Auto.**



**Figure 126.**

## 11.4. Generator Ready

Once the above steps are completed the generator is set up and ready. This means that in the event of a power cut the critical circuits will continue to work through battery power until the battery runs to the SOC (State of charge) limit set. The generator will then turn on and continue to provide power for the critical circuits and charge the battery back up to the desired SOC. This will repeat until the grid is reestablished. Once the grid has been reestablished then the generator will stop providing power, wait for the grid to be stable then shut off.



Figure 127. Generator web monitoring



**CAUTION**

An earth spike is a requirement for the generator. This will help frequency balancing for the critical circuits and battery charge. If there is a loss of AC supply an earth spike will also help prevent islanding.

## 11.5. Recommendations

A changeover switch is recommended for critical circuits. This will ensure minimal disruption of the supply for the critical circuits during inverter maintenance.

Remind the customer to keep their generator serviced regularly and topped up with fuel and oil.

## 12. Maintenance

### 12.1. LED Introduction

Button holding time	Function
1s	Clear the overload alarm
5s	ON/OFF inverter

**Figure 128.** Button on LED

This section describes the LED panel. LED indicators include a green, blue and red LED indicator. shows the explanation of indicator states.

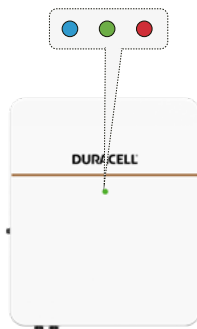

LED Indicator	Status	Description
Green LED	On	On-Grid status
	Blink	Standby status
Blue LED	On	Off-Grid status
Red LED	On	Fault has occurred
	Light alternately (1 color /0.25s)	Burning code

**Figure 129.**

### 12.2. LAN/Wi-Fi Dongle LED status

LED	Dongle Status
Green LED	Normal Communication
Red LED	Inverter connection failure

LED	Dongle Status
Yellow LED	Router connection failure
Blue LED	Server connection failure
LAN LED - White	LAN connection

**Figure 130.** LAN/Wi-Fi dongle LED status



**Figure 131.**

### 12.3. Routine Maintenance



**CAUTION**

Before maintaining and commissioning the inverter and its distribution unit, switch off all the charged terminals of the inverter and wait at least 10 minutes after the inverter is powered off.

Items	Checks	Maintenance	Maintenance Interval
Inverter cleaning	Periodically check that the heat sink is free from dust and blockages.	Periodically clean the heat sink.	Annually
Inverter running status	Check that the inverter for damage. Check for normal sound emitted during inverter operation. Check and ensure that all inverter communications is running well.	If there is any abnormal phenomenon, contact Customer Services.	Monthly
Inverter electrical connections	Check that all AC, DC and communication cables are securely connected; Check that PGND cables are securely connected; Check that all cables are intact and free from aging.	If there is any abnormal phenomenon, contact Customer Services.	Twice a year

**Figure 132.**

## 12.4. Establishing a Local Connection via Bluetooth - Installer

Open the Dura-i App and follow the steps below to establish a local connection.

### Step 1. Log in to the App.

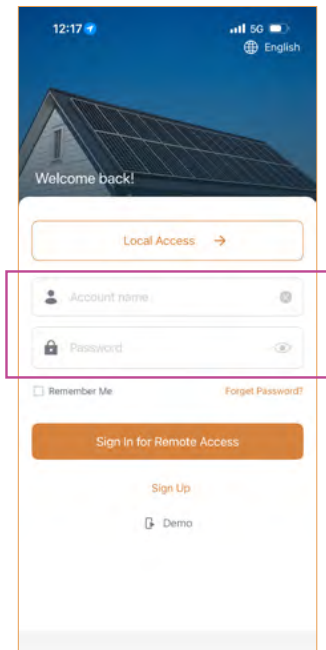

Figure 133.

### Step 2. Select 'Bluetooth' in the bottom left corner.

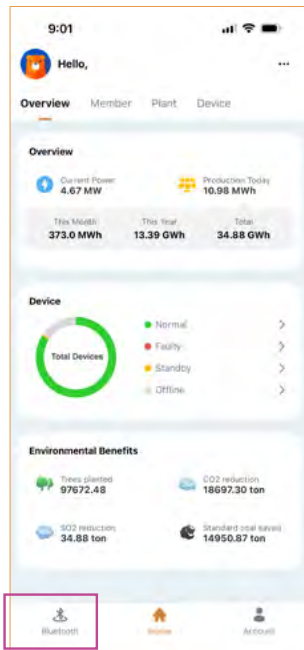

Figure 134.

**Step 3.** Select the inverter you are trying to connect to.

**Step 4.** Tap on the 'Setting' icon.

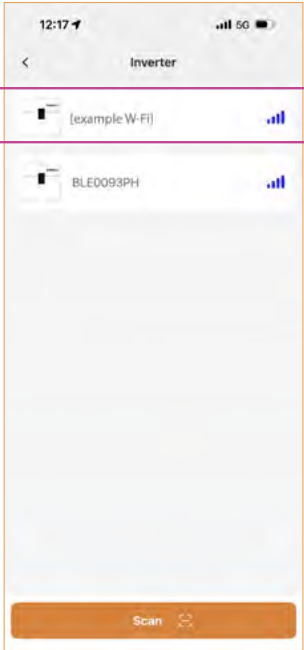

Figure 135.

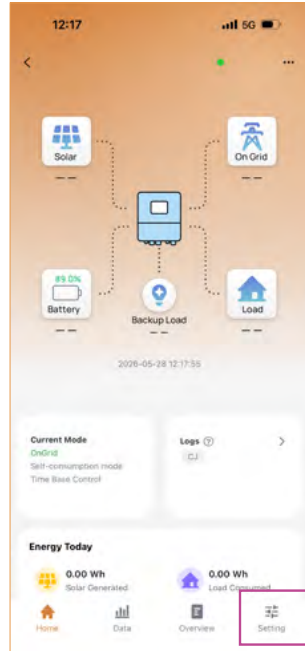
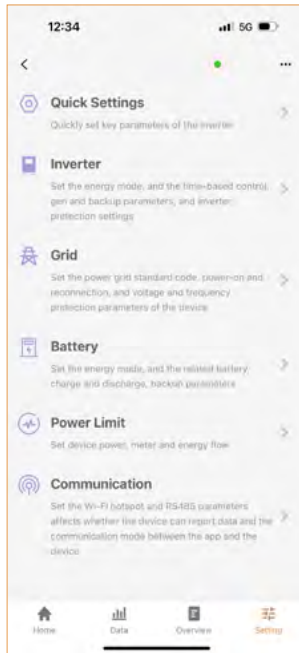

Figure 136.

**Step 5.** You now have access. In the settings screen you can make your required changes.



**Figure 137.**

## 12.5. Establishing a Local Connection via Bluetooth - Consumer/End User

Please download and install the **Dura-i App** and follow the steps below to establish a local connection. You will not need login details.



NOTE

The **Dura-i App** is normally for installers only and is used to commission systems. This is different to the **Duracell Energy App**, which is designed specifically for the End User to control and monitor your system at home.

Scan the following QR code to download the **Dura-i App**.

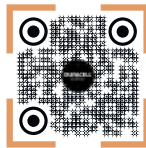
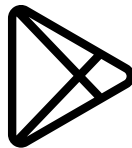

**Step 1. Open the app and select 'Local Access'**

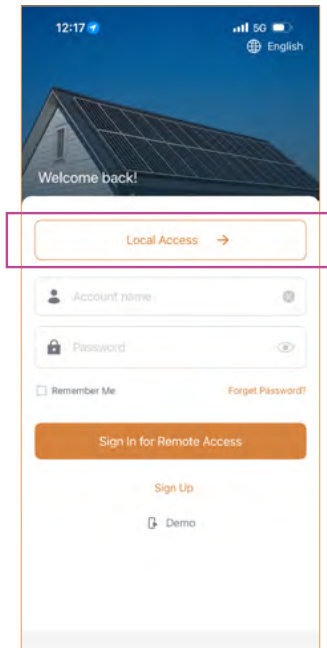

Figure 138.

**Step 2.** Select the inverter you are trying to connect to.

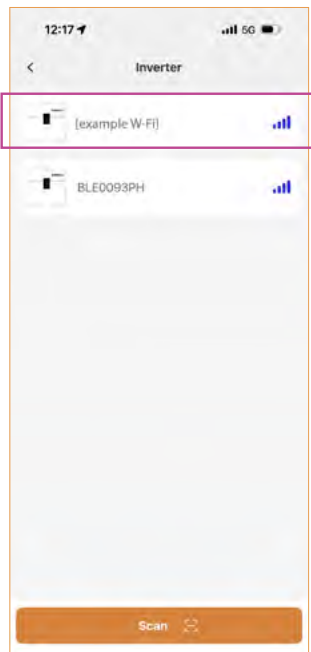

Figure 139.

**Step 3.** Tap on the arrow beside 'End User' for access.

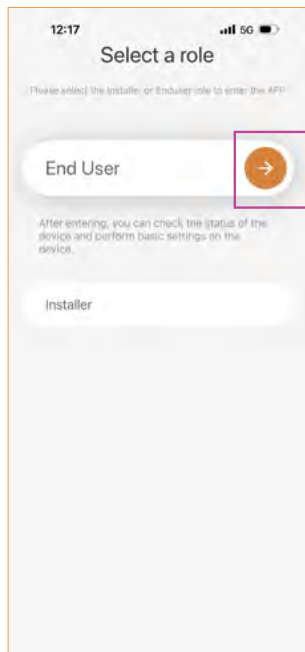

Figure 140.

**Step 4.** Tap on the 'Setting' icon in the bottom right.



Figure 141.

**Step 5. These are the settings you can access.**

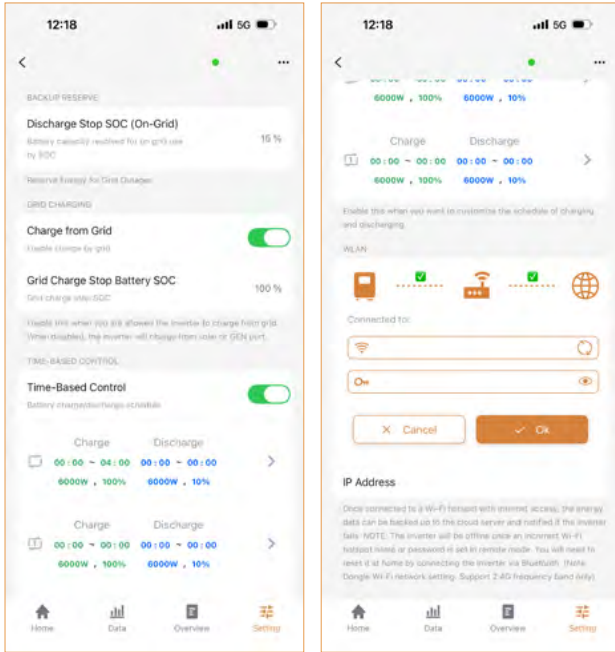

Figure 142.

## 12.6. Connecting/Reconnecting to Wi-Fi Network - Consumer/End User

**Step 1.** Ensure your phone is already connected to the specific Wi-Fi network you want to pair your system with.

**Step 2.** Follow the previous steps in **Section** to establish a local connection via Bluetooth.



NOTE

Red crosses **✗** will show if you are not connected to the Wi-Fi or internet.

**Step 3.** Wi-Fi network name should prepopulate on the below app screen. Enter Wi-Fi password and tap 'Ok'.



**Figure 143.**

**Step 4.** Once you have pressed 'Ok' a 300 second timer will appear and begin to count down. Before the timer hits zero the green ticks **✔** will appear indicating Wi-Fi configuration is complete.

# 13. Inverter Troubleshooting

## 13.1. Alarm States

When the inverter is in an alarm state, you will be able to see the details when locally connected and on the Dura-i App. The various alert codes and suggested corrective actions are shown in the table below.

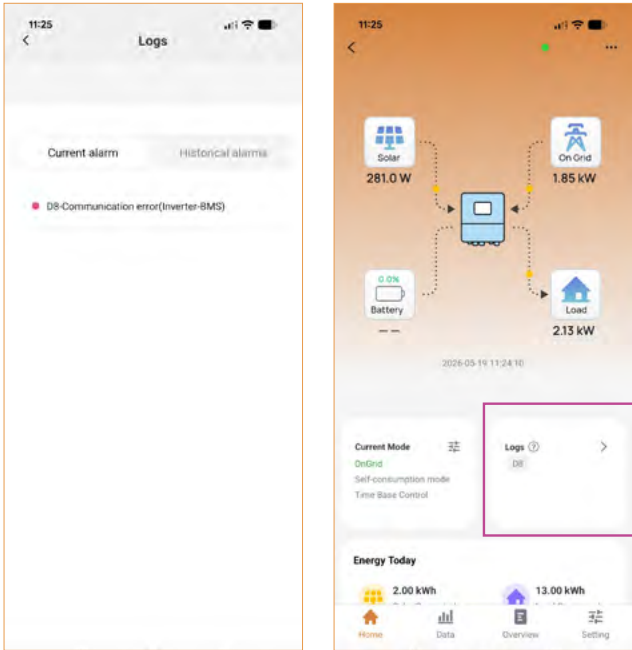

Figure 144. Live usage chart alert. (Example shown, CJ - see table below)

Fault	Meaning	Common Cause / Remedy	
A0	Grid over voltage	<ol style="list-style-type: none"> <li>1. If the alarm occurs occasionally, possibly the power grid voltage is abnormal temporarily, and no action is required.</li> <li>2. If the alarm occurs consistently check the grid voltage manually with a multi-meter.</li> <li>3. If the customer has multiple inverters on the same phase, synchronised discharge of batteries can cause grid voltage to increase slightly above threshold. To eliminate this alarm, prevent multiple inverters from discharging into the grid at the same time. If this is not an option, contact customer services.</li> <li>4. If the alarm occurs repeatedly, contact the local power station. After receiving approval of the local power bureau, revise the electrical protection parameter settings on the inverter through the App.</li> <li>5. If the alarm persists for a long time, check whether the AC circuit breaker /AC terminals is disconnected, or if the grid has a power outage.</li> <li>6. If the grid voltage is normal and the alarm persists, contact customer services.</li> </ol>	
A1	Grid under voltage		
A3	Grid over frequency		
A4	Grid under frequency		
A2	Grid absent		Wait until power is restored.

Fault	Meaning	Common Cause/Remedy
A9	AC Live & Neutral reversed	<ol style="list-style-type: none"> <li>1. Check the wiring in the AC Grid Connector plug, ensuring cables aren't crossed polarity.</li> <li>2. Ensure no AC Voltage is incoming between Neutral and Earth. If there is, installer will need to check the wiring upstream of the inverter.</li> </ol> <div style="display: flex; align-items: center; margin-top: 10px;"> <p><b>NOTICE</b> If left without a corrective action this could potentially lead to a C3 alarm (where a component has blown on the inverter board) meaning a replacement unit may be necessary.</p> </div>
B0	PV over voltage	Check whether the maximum input voltage of a single PV string exceeds the MPPT working voltage. If yes, modify the number of PV module connection strings.
B1	PV insulation abnormal	<ol style="list-style-type: none"> <li>1. Check the insulation resistance against the ground for the PV strings. If a short circuit has occurred, rectify the fault.</li> <li>2. If the insulation resistance against the ground is less than the default value in a rainy environment, set insulation resistance protection on the App.</li> </ol>
B2	Leakage current abnormal	<ol style="list-style-type: none"> <li>1. If the alarm occurs occasionally, the inverter should automatically return to normal functionality after the fault is rectified.</li> <li>2. If the alarm occurs repeatedly, contact customer services for technical support.</li> </ol>
B4	PV under voltage	<ol style="list-style-type: none"> <li>1. If the alarm occurs occasionally, possibly the external circuits are abnormal accidentally. The inverter automatically recovers to normal operating status after the fault is rectified.</li> <li>2. If the alarm occurs repeatedly or lasts a long time, check whether the insulation resistance against the ground of PV strings is too low.</li> </ol>
B7	PV string reverse	1. Check and correct the polarity of the PV string.
C0	Internal power supply abnormal	<ol style="list-style-type: none"> <li>1. If the alarm occurs occasionally, the inverter automatically recovers to normal operating status, and no action is required.</li> <li>2. If the alarm occurs repeatedly, please contact customer services.</li> </ol>
C2	Inverter over DC-bias current	<ol style="list-style-type: none"> <li>1. If the alarm occurs occasionally, possibly the power grid voltage is abnormal temporarily, and no action is required.</li> <li>2. If the alarm occurs repeatedly, and the inverter fails to generate power, contact customer services</li> </ol>
C3	Inverter relay abnormal	<ol style="list-style-type: none"> <li>1. Check if live and neutral are the right way around in the grid plug.</li> <li>2. If the alarm occurs occasionally, possibly the power grid voltage is abnormal temporarily, and no action is required.</li> <li>2. If the alarm occurs repeatedly, please refer to the remedy for 'Grid over voltage' (A0). If there is no abnormality on the grid side, a machine fault may be indicated. If the inverter fails to generate power, contact customer services.</li> </ol>
CN	Remote off	<ol style="list-style-type: none"> <li>1. Local manual shutdown is performed in the App.</li> <li>2. The monitor executed the remote shutdown instruction.</li> <li>3. Remove the communication module and confirm whether the alarm disappears. If yes, replace the communication module. Otherwise, please contact customer services.</li> </ol>
C5	Inverter over temperature	<ol style="list-style-type: none"> <li>1. If the alarm occurs occasionally, the inverter should automatically recover. No action is required.</li> <li>2. If the alarm occurs repeatedly, please check whether the installation site has direct sunlight, bad ventilation, or high ambient temperature (such as installed on the parapet). Yet, if the ambient temperature is lower than 45°C and the heat dissipation and ventilation is good, please contact customer services.</li> </ol>
C6	GFCI abnormal	<ol style="list-style-type: none"> <li>1. If the alarm occurs occasionally, it could have been an occasional exception to the external wiring. The inverter should automatically recover. No action is required.</li> <li>2. If it occurs repeatedly please contact customer services.</li> </ol>

Fault	Meaning	Common Cause/Remedy
C8	Fan abnormal	<ol style="list-style-type: none"> <li>1. If the alarm occurs occasionally, please restart the inverter.</li> <li>2. If it occurs repeatedly or cannot be recovered for a long time, check whether the external fan is blocked by foreign objects. Otherwise, contact customer services.</li> </ol>
C9	DC link unbalance or under voltage	<p>The batteries exceeded their current discharge limit.</p> <ol style="list-style-type: none"> <li>1. If the alarm triggers occasionally, no action is required.</li> <li>2. If the alarm triggers repeatedly, please contact customer service.</li> </ol>
CA	DC-link over voltage	<ol style="list-style-type: none"> <li>1. If the alarm occurs occasionally, the inverter should automatically return to normal functionality and no action is required.</li> <li>2. If the alarm occurs repeatedly, the inverter cannot work properly. Please contact customer services.</li> </ol>
CB	Internal communication error	<ol style="list-style-type: none"> <li>1. If the alarm occurs occasionally, the inverter should automatically return to normal functionality and no action is required.</li> <li>2. If the alarm occurs repeatedly, the inverter cannot work properly. Contact customer services.</li> </ol>
CC	Software incompatibility	<ol style="list-style-type: none"> <li>1. If the alarm occurs occasionally, the inverter should automatically return to normal functionality and no action is required.</li> <li>2. If the alarm occurs repeatedly, the inverter cannot work properly. Contact customer services.</li> </ol>
CD	Internal storage error	<ol style="list-style-type: none"> <li>1. If the alarm occurs occasionally, the inverter should automatically return to normal functionality and no action is required.</li> <li>2. If the alarm occurs repeatedly, the inverter cannot work properly. Contact customer services.</li> </ol>
CE	Data inconsistency	<ol style="list-style-type: none"> <li>1. If the alarm occurs occasionally, the inverter should automatically return to normal functionality and no action is required.</li> <li>2. If the alarm occurs repeatedly, the inverter cannot work properly. Contact customer services.</li> </ol>
CF	Inverter abnormal	<ol style="list-style-type: none"> <li>1. If the alarm occurs occasionally, the inverter should automatically return to normal functionality and no action is required.</li> <li>2. If the alarm occurs repeatedly, the inverter cannot work properly. Contact customer services.</li> </ol>
CG	Boost abnormal	<ol style="list-style-type: none"> <li>1. If the alarm occurs occasionally, the inverter should automatically return to normal functionality and no action is required.</li> <li>2. If the alarm occurs repeatedly, the inverter cannot work properly. Contact customer services.</li> </ol>
CJ	Meter lost	<p><b>CT</b></p> <ol style="list-style-type: none"> <li>1. Check the CT clamp is installed correctly and in the correct port on the inverter.</li> <li>2. Check the clamp is fully closed around the live of the AC grid supply.</li> <li>3. If CT is extended ensure you adhere to distances in <b>Figure 52. Available options for grid monitoring (p39).</b></li> </ol> <p><b>REM</b></p> <ol style="list-style-type: none"> <li>1. Check that the modbus communication address of the energy meter is consistent with that of the inverter.</li> <li>2. The communication line is connected incorrectly or in bad contact.</li> </ol>
		 <p><b>NOTE</b> Check the CT ratio matches that of the meter.</p>

Fault	Meaning	Common Cause / Remedy
CU	DC abnormal	<ol style="list-style-type: none"> <li>1. If the alarm occurs occasionally, the inverter should automatically return to normal functionality and no action is required.</li> <li>2. If the alarm occurs repeatedly, please check:               <ol style="list-style-type: none"> <li>1) Check whether the MC4 terminal on the PV side is securely connected.</li> <li>2) Check whether the voltage at the PV side is open circuit, ground to ground, etc. Having checked the above, if the alarm continues to occur, please contact customer services.</li> </ol> </li> </ol>
CP	AC output over DC-bias voltage	<ol style="list-style-type: none"> <li>1. If the alarm occurs occasionally, the inverter should automatically return to normal functionality and no action is required.</li> <li>2. If the alarm occurs repeatedly, the inverter cannot work properly. Contact customer services.</li> </ol>
D2	Battery over voltage	<ol style="list-style-type: none"> <li>1. If the alarm occurs occasionally, the inverter should automatically return to normal functionality and no action is required.</li> <li>2. Check that the battery overvoltage protection value is set correctly.</li> <li>3. The battery voltage is abnormal.</li> <li>4. Having checked the above, if the alarm continues to occur, please contact customer services.</li> </ol>
D3	Battery under voltage	<ol style="list-style-type: none"> <li>1. If the alarm occurs occasionally, the inverter should automatically return to normal functionality and no action is required.</li> <li>2. Check the communication line connection between BMS and inverter (the Dura5 battery).</li> <li>3. The battery is empty or the battery voltage is lower than the SOC cutoff voltage.</li> <li>4. The battery undervoltage protection value is improperly set.</li> <li>5. Check that the battery positive and negative are connected properly.</li> <li>6. Check that the DC isolator switch on the battery is on.</li> <li>7. Having checked the above, if the alarm continues to occur, please contact customer services.</li> </ol>
D4	Battery discharger over current	<ol style="list-style-type: none"> <li>1. Check whether the battery parameters are correctly set.</li> <li>2. Battery undervoltage.</li> <li>3. Check whether a separate battery is loaded and the discharge current exceeds the battery specifications.</li> <li>4. The battery is abnormal.</li> <li>5. Having checked the above, if the alarm continues to occur, please contact customer services.</li> </ol>
D5	Battery over temperature	<ol style="list-style-type: none"> <li>1. If the alarm occurs repeatedly, please check whether the installation site is in direct sunlight and whether the ambient temperature is too high (such as in a closed room).</li> </ol>
D6	Battery under temperature	<ol style="list-style-type: none"> <li>2. If the battery is abnormal, replace it with a new one.</li> <li>3. Having checked the above, if the alarm continues to occur, please contact customer services.</li> </ol>
D7	AC output voltage abnormal	<ol style="list-style-type: none"> <li>1. Check whether the AC OUTPUT voltage and frequency Settings are within the specified range.</li> <li>2. Check whether the AC OUTPUT circuit is overloaded.</li> <li>3. When not connected to the power grid, check whether AC OUTPUT voltage is normal.</li> <li>4. Having checked the above, if the alarm continues to occur, please contact customer services.</li> </ol>
D8	Communication error (Inverter-BMS)	<ol style="list-style-type: none"> <li>1. Check the battery is connected correctly using the provided grey battery to inverter cable and that the labelled ends correspond with the device they are connected to. <b>DO NOT USE THE BLACK COMS CABLE PROVIDED WITH THE BATTERY.</b></li> <li>2. Check that the correct battery type is selected in Battery select.</li> <li>3. Check that the battery is switched on and the DC isolator is also on.</li> </ol>

Fault	Meaning	Common Cause/Remedy
D9	Internal communication loss(E-M)	1. Check whether the communication cables between AC OUTPUT, electricity meter and inverter are well connected and whether the wiring is correct (European units only).
DA	Internal communication loss(M-D)	2. Check whether the communication distance is within the specified range 3. Disconnect the external communication and restart the electricity meter and inverter. 4. Having checked the above, if the alarm continues to occur, please contact customer services.
DB	AC output short circuit	1. Check whether the live line and neutral line of AC OUTPUT are short-circuited. 2. If it is confirmed that the output is not short-circuited or an alarm, please contact customer service to report for repair. (After the troubleshooting of alarm problems, AC OUTPUT breaker needs to be manually turned on during normal use.)
DC	AC output over load	1. Disconnect the AC OUTPUT breaker and check whether the alarm is cleared. 2. If the load is disconnected and the alarm is generated, please contact customer services. (After the alarm is cleared, the AC OUT breaker needs to be manually turned on for normal use.)
DO	Meter 2 lost or device communication loss	1. Check the meter parameter Settings 2. Local App checks that the communication address of the inverter is consistent with that of the electricity meter 3. The communication line is connected incorrectly or in bad contact 4. Electricity meter failure. 5. Excluding the above, if the alarm continues to occur, please contact customer services.
P1	Parallel ID warning	Parallel ID Alarm. Check the parallel communication cable. Ensure all inverters are powered off completely, check the line, and then power on the inverters again to ensure that the alarm is cleared.
P2	Parallel SYN signal warning	Parallel synchronization signal is abnormal. Check whether the parallel communication cable is properly connected.
P3	Parallel BAT abnormal	The parallel battery is abnormal. Whether the battery of the inverter is reported low voltage or the battery is not connected.
P4	Parallel GRID abnormal	The parallel grid is abnormal.
P5	Phase Sequence abnormal	Ensure that the phase sequence of power grid is consistent with that of L1/L2/L3 in the App. To clear Phase Sequence abnormal alarm: <b>Option 1:</b> Power off all inverters, correct the phase sequence of each inverter and then restart the inverters. <b>Option 2:</b> Under inverter standby mode, correct the phase sequence of each inverter on App, power off all inverters and then restart the inverters. If the alarm continues, please contact customer services.

## 13.2. Removing the Inverter

 **WARNING** Before removing DC input connector, double check the DC input switch is turned to OFF to avoid inverter damage and personal injury.

Perform the following procedures to remove the inverter:

**Step 1. Disconnect all cables from the inverter, including communications cables, DC input power cables, AC output power cables, and earth bonding cable.**

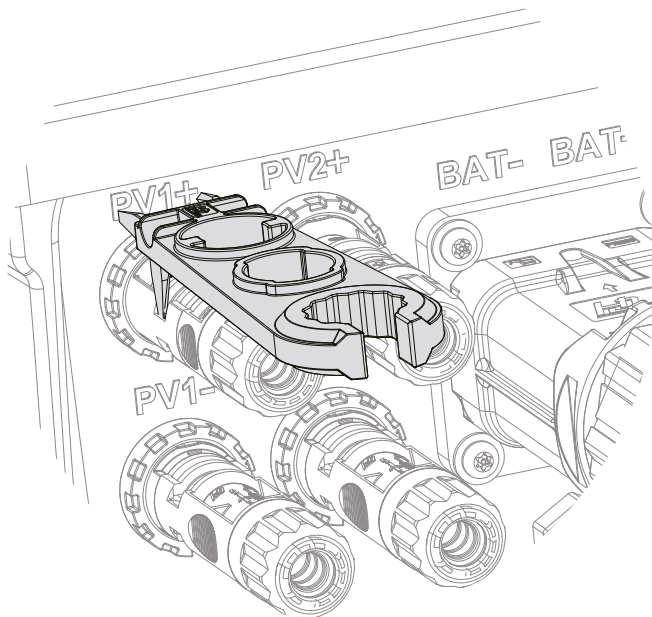

*Figure 145. Removing PV Connectors*

**Step 2. Remove the mounting bracket.**

## 14. Customer Service Contact Information

If you are experiencing issues with your install which cannot be answered by the information in this guide you can contact customer services using the information listed below:

**Tel:** 0808 281 2855. Please refer to our website for current opening hours.

**Email:** [support.uk@duracellenergy.com](mailto:support.uk@duracellenergy.com)

**Web Form:** [www.duracellenergy.com/contact-us](http://www.duracellenergy.com/contact-us)



# DURACELL<sup>®</sup> ENERGY



## Get in touch...

@ support.uk@duracellenergy.com

☎ 01386 577845

🌐 www.duracellenergy.com

## EU Authorised Representative address:

Comply Express Unipessoal Limitada,  
StartUp Madeira,  
EV141,  
Campus da Penteadá,  
9020 105 Funchal,  
Portugal

Duracell is a registered trademark of Duracell Batteries BV and Duracell U.S. Operations, Inc., used under license. All rights reserved. Manufactured under license and warranty supported by Puredrive Energy Limited in Toddington, Gloucestershire, UK.

**Note:** NEITHER DURACELL BATTERIES BV, DURACELL U.S. OPERATIONS, INC., NOR ITS AFFILIATES ARE INVOLVED IN THE DESIGN, MANUFACTURE, MARKETING OR DISTRIBUTION OF THE PRODUCTS AND THEY DO NOT MAKE ANY (AND HEREBY DISCLAIM ALL) EXPRESS OR IMPLIED WARRANTIES RELATING TO THE PRODUCTS.